

## Chapter 17

# Advanced Uses of Pointers

## Dynamic Storage Allocation

- C's data structures, including arrays, are normally fixed in size.
- Fixed-size data structures can be a problem, since we're forced to choose their sizes when writing a program.
- Fortunately, C supports *dynamic storage allocation*: the ability to allocate storage during program execution.
- Using dynamic storage allocation, we can design data structures that grow (and shrink) as needed.

## Dynamic Storage Allocation

- Dynamic storage allocation is used most often for strings, arrays, and structures.
- Dynamically allocated structures can be linked together to form lists, trees, and other data structures.
- Dynamic storage allocation is done by calling a memory allocation function.

## Memory Allocation Functions

- The `<stdlib.h>` header declares three memory allocation functions:

`malloc`—Allocates a block of memory but doesn't initialize it.

`calloc`—Allocates a block of memory and clears it.

`realloc`—Resizes a previously allocated block of memory.

- These functions return a value of type `void *` (a “generic” pointer).

## Null Pointers

- If a memory allocation function can't locate a memory block of the requested size, it returns a *null pointer*.
- A null pointer is a special value that can be distinguished from all valid pointers.
- After we've stored the function's return value in a pointer variable, we must test to see if it's a null pointer.

## Null Pointers

- An example of testing `malloc`'s return value:

```
p = malloc(10000);  
if (p == NULL) {  
    /* allocation failed; take appropriate action */  
}
```

- `NULL` is a macro (defined in various library headers) that represents the null pointer.
- Some programmers combine the call of `malloc` with the `NULL` test:

```
if ((p = malloc(10000)) == NULL) {  
    /* allocation failed; take appropriate action */  
}
```

## Null Pointers

- Pointers test true or false in the same way as numbers.
- All non-null pointers test true; only null pointers are false.

- Instead of writing

```
if (p == NULL) ...
```

we could write

```
if (!p) ...
```

- Instead of writing

```
if (p != NULL) ...
```

we could write

```
if (p) ...
```

## Dynamically Allocated Strings

- Dynamic storage allocation is often useful for working with strings.
- Strings are stored in character arrays, and it can be hard to anticipate how long these arrays need to be.
- By allocating strings dynamically, we can postpone the decision until the program is running.



## Using `malloc` to Allocate Memory for a String

- Prototype for the `malloc` function:

```
void *malloc(size_t size);
```

- `malloc` allocates a block of `size` bytes and returns a pointer to it.
- `size_t` is an unsigned integer type defined in the library.

## Using `malloc` to Allocate Memory for a String

- A call of `malloc` that allocates memory for a string of `n` characters:

```
p = malloc(n + 1);
```

`p` is a `char *` variable.

- Each character requires one byte of memory; adding 1 to `n` leaves room for the null character.
- Some programmers prefer to cast `malloc`'s return value, although the cast is not required:

```
p = (char *) malloc(n + 1);
```

## Using `malloc` to Allocate Memory for a String

- Memory allocated using `malloc` isn't cleared, so `p` will point to an uninitialized array of  $n + 1$  characters:

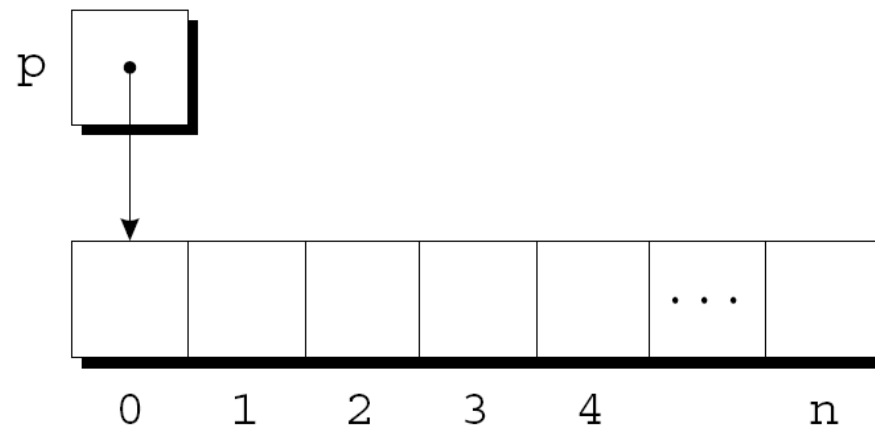

## Using `malloc` to Allocate Memory for a String

- Calling `strcpy` is one way to initialize this array:  
`strcpy(p, "abc");`
- The first four characters in the array will now be a, b, c, and `\0`:

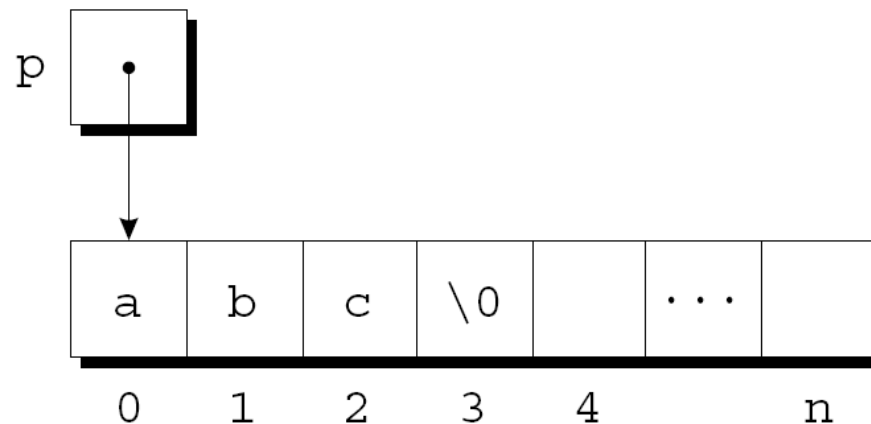

## Using Dynamic Storage Allocation in String Functions

- Dynamic storage allocation makes it possible to write functions that return a pointer to a “new” string.
- Consider the problem of writing a function that concatenates two strings without changing either one.
- The function will measure the lengths of the two strings to be concatenated, then call `malloc` to allocate the right amount of space for the result.

## Using Dynamic Storage Allocation in String Functions

```
char *concat(const char *s1, const char *s2)
{
    char *result;

    result = malloc(strlen(s1) + strlen(s2) + 1);
    if (result == NULL) {
        printf("Error: malloc failed in concat\n");
        exit(EXIT_FAILURE);
    }
    strcpy(result, s1);
    strcat(result, s2);
    return result;
}
```

## Using Dynamic Storage Allocation in String Functions

- A call of the `concat` function:  

```
p = concat("abc", "def");
```
- After the call, `p` will point to the string `"abcdef"`, which is stored in a dynamically allocated array.

## Using Dynamic Storage Allocation in String Functions

- Functions such as `concat` that dynamically allocate storage must be used with care.
- When the string that `concat` returns is no longer needed, we'll want to call the `free` function to release the space that the string occupies.
- If we don't, the program may eventually run out of memory.



## Program: Printing a One-Month Reminder List (Revisited)

- The `remind2.c` program is based on the `remind.c` program of Chapter 13, which prints a one-month list of daily reminders.
- The original `remind.c` program stores reminder strings in a two-dimensional array of characters.
- In the new program, the array will be one-dimensional; its elements will be pointers to dynamically allocated strings.

## Program: Printing a One-Month Reminder List (Revisited)

- Advantages of switching to dynamically allocated strings:
  - Uses space more efficiently by allocating the exact number of characters needed to store a reminder.
  - Avoids calling `strcpy` to move existing reminder strings in order to make room for a new reminder.
- Switching from a two-dimensional array to an array of pointers requires changing only eight lines of the program (shown in **bold**).

## Chapter 17: Advanced Uses of Pointers

### remind2.c

```
/* Prints a one-month reminder list (dynamic string version) */

#include <stdio.h>
#include <stdlib.h>
#include <string.h>

#define MAX_REMIND 50    /* maximum number of reminders */
#define MSG_LEN 60      /* max length of reminder message */

int read_line(char str[], int n);
int main(void)
{
    char *reminders[MAX_REMIND];
    char day_str[3], msg_str[MSG_LEN+1];
    int day, i, j, num_remind = 0;
```

## Chapter 17: Advanced Uses of Pointers

```
for (;;) {
    if (num_remind == MAX_REMIND) {
        printf("-- No space left --\n");
        break;
    }

    printf("Enter day and reminder: ");
    scanf("%2d", &day);
    if (day == 0)
        break;
    sprintf(day_str, "%2d", day);
    read_line(msg_str, MSG_LEN);

    for (i = 0; i < num_remind; i++)
        if (strcmp(day_str, reminders[i]) < 0)
            break;
    for (j = num_remind; j > i; j--)
        reminders[j] = reminders[j-1];
}
```

## Chapter 17: Advanced Uses of Pointers

```
reminders[i] = malloc(2 + strlen(msg_str) + 1);
if (reminders[i] == NULL) {
    printf("-- No space left --\n");
    break;
}

strcpy(reminders[i], day_str);
strcat(reminders[i], msg_str);

num_remind++;
}

printf("\nDay Reminder\n");
for (i = 0; i < num_remind; i++)
    printf(" %s\n", reminders[i]);

return 0;
}
```

## Chapter 17: Advanced Uses of Pointers

```
int read_line(char str[], int n)
{
    int ch, i = 0;

    while ((ch = getchar()) != '\n')
        if (i < n)
            str[i++] = ch;
    str[i] = '\0';
    return i;
}
```

## Dynamically Allocated Arrays

- Dynamically allocated arrays have the same advantages as dynamically allocated strings.
- The close relationship between arrays and pointers makes a dynamically allocated array as easy to use as an ordinary array.
- Although `malloc` can allocate space for an array, the `calloc` function is sometimes used instead, since it initializes the memory that it allocates.
- The `realloc` function allows us to make an array “grow” or “shrink” as needed.

## Using `malloc` to Allocate Storage for an Array

- Suppose a program needs an array of `n` integers, where `n` is computed during program execution.
- We'll first declare a pointer variable:

```
int *a;
```

- Once the value of `n` is known, the program can call `malloc` to allocate space for the array:

```
a = malloc(n * sizeof(int));
```

- Always use the `sizeof` operator to calculate the amount of space required for each element.



## Using `malloc` to Allocate Storage for an Array

- We can now ignore the fact that `a` is a pointer and use it instead as an array name, thanks to the relationship between arrays and pointers in C.
- For example, we could use the following loop to initialize the array that `a` points to:

```
for (i = 0; i < n; i++)  
    a[i] = 0;
```

- We also have the option of using pointer arithmetic instead of subscripting to access the elements of the array.

## The `calloc` Function

- The `calloc` function is an alternative to `malloc`.
- Prototype for `calloc`:

```
void *calloc(size_t nmemb, size_t size);
```
- Properties of `calloc`:
  - Allocates space for an array with `nmemb` elements, each of which is `size` bytes long.
  - Returns a null pointer if the requested space isn't available.
  - Initializes allocated memory by setting all bits to 0.

## The `calloc` Function

- A call of `calloc` that allocates space for an array of `n` integers:

```
a = calloc(n, sizeof(int));
```

- By calling `calloc` with 1 as its first argument, we can allocate space for a data item of any type:

```
struct point { int x, y; } *p;
```

```
p = calloc(1, sizeof(struct point));
```

## The `realloc` Function

- The `realloc` function can resize a dynamically allocated array.
- Prototype for `realloc`:  

```
void *realloc(void *ptr, size_t size);
```
- `ptr` must point to a memory block obtained by a previous call of `malloc`, `calloc`, or `realloc`.
- `size` represents the new size of the block, which may be larger or smaller than the original size.

## The `realloc` Function

- Properties of `realloc`:
  - When it expands a memory block, `realloc` doesn't initialize the bytes that are added to the block.
  - If `realloc` can't enlarge the memory block as requested, it returns a null pointer; the data in the old memory block is unchanged.
  - If `realloc` is called with a null pointer as its first argument, it behaves like `malloc`.
  - If `realloc` is called with 0 as its second argument, it frees the memory block.

## The `realloc` Function

- We expect `realloc` to be reasonably efficient:
  - When asked to reduce the size of a memory block, `realloc` should shrink the block “in place.”
  - `realloc` should always attempt to expand a memory block without moving it.
- If it can't enlarge a block, `realloc` will allocate a new block elsewhere, then copy the contents of the old block into the new one.
- Once `realloc` has returned, be sure to update all pointers to the memory block in case it has been moved.

## Deallocating Storage

- `malloc` and the other memory allocation functions obtain memory blocks from a storage pool known as the *heap*.
- Calling these functions too often—or asking them for large blocks of memory—can exhaust the heap, causing the functions to return a null pointer.
- To make matters worse, a program may allocate blocks of memory and then lose track of them, thereby wasting space.

## Deallocating Storage

- Example:

```
p = malloc (...);
```

```
q = malloc (...);
```

```
p = q;
```

- A snapshot after the first two statements have been executed:

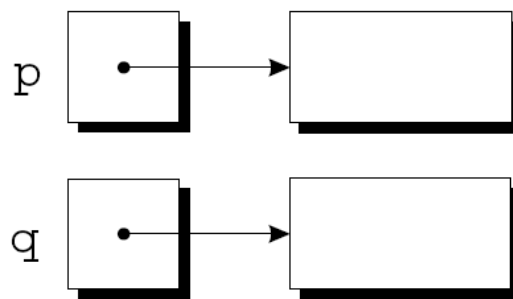



## Deallocating Storage

- After  $q$  is assigned to  $p$ , both variables now point to the second memory block:

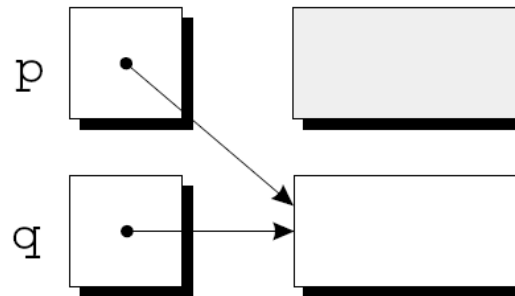

- There are no pointers to the first block, so we'll never be able to use it again.

## Deallocating Storage

- A block of memory that's no longer accessible to a program is said to be *garbage*.
- A program that leaves garbage behind has a *memory leak*.
- Some languages provide a *garbage collector* that automatically locates and recycles garbage, but C doesn't.
- Instead, each C program is responsible for recycling its own garbage by calling the `free` function to release unneeded memory.

## The `free` Function

- Prototype for `free`:

```
void free(void *ptr);
```

- `free` will be passed a pointer to an unneeded memory block:

```
p = malloc(...);  
q = malloc(...);  
free(p);  
p = q;
```

- Calling `free` releases the block of memory that `p` points to.

## The “Dangling Pointer” Problem

- Using `free` leads to a new problem: *dangling pointers*.
- `free(p)` deallocates the memory block that `p` points to, but doesn't change `p` itself.
- If we forget that `p` no longer points to a valid memory block, chaos may ensue:

```
char *p = malloc(4);  
...  
free(p);  
...  
strcpy(p, "abc");    /*** WRONG ***/
```

- Modifying the memory that `p` points to is a serious error.

## The “Dangling Pointer” Problem

- Dangling pointers can be hard to spot, since several pointers may point to the same block of memory.
- When the block is freed, all the pointers are left dangling.

## Linked Lists

- Dynamic storage allocation is especially useful for building lists, trees, graphs, and other linked data structures.
- A *linked list* consists of a chain of structures (called *nodes*), with each node containing a pointer to the next node in the chain:

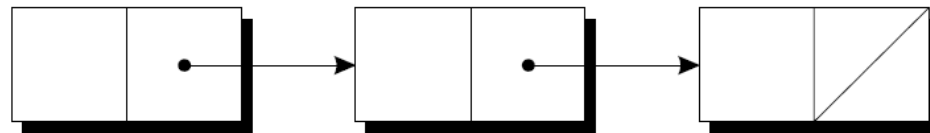

- The last node in the list contains a null pointer.

## Linked Lists

- A linked list is more flexible than an array: we can easily insert and delete nodes in a linked list, allowing the list to grow and shrink as needed.
- On the other hand, we lose the “random access” capability of an array:
  - Any element of an array can be accessed in the same amount of time.
  - Accessing a node in a linked list is fast if the node is close to the beginning of the list, slow if it’s near the end.

## Declaring a Node Type

- To set up a linked list, we'll need a structure that represents a single node.
- A node structure will contain data (an integer in this example) plus a pointer to the next node in the list:

```
struct node {  
    int value;           /* data stored in the node */  
    struct node *next; /* pointer to the next node */  
};
```

- node must be a tag, not a typedef name, or there would be no way to declare the type of next.



## Declaring a Node Type

- Next, we'll need a variable that always points to the first node in the list:

```
struct node *first = NULL;
```

- Setting `first` to `NULL` indicates that the list is initially empty.

## Creating a Node

- As we construct a linked list, we'll create nodes one by one, adding each to the list.
- Steps involved in creating a node:
  1. Allocate memory for the node.
  2. Store data in the node.
  3. Insert the node into the list.
- We'll concentrate on the first two steps for now.

## Creating a Node

- When we create a node, we'll need a variable that can point to the node temporarily:

```
struct node *new_node;
```

- We'll use `malloc` to allocate memory for the new node, saving the return value in `new_node`:

```
new_node = malloc(sizeof(struct node));
```

- `new_node` now points to a block of memory just large enough to hold a node structure:

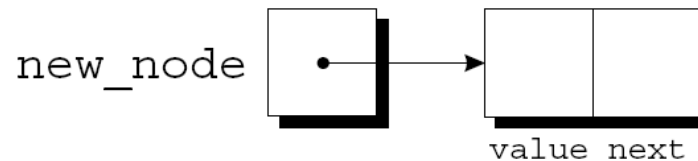

## Creating a Node

- Next, we'll store data in the `value` member of the new node:

```
(*new_node).value = 10;
```

- The resulting picture:

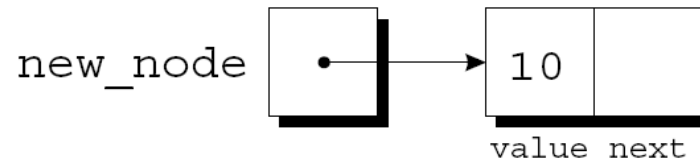

- The parentheses around `*new_node` are mandatory because the `.` operator would otherwise take precedence over the `*` operator.

## The `->` Operator

- Accessing a member of a structure using a pointer is so common that C provides a special operator for this purpose.
- This operator, known as *right arrow selection*, is a minus sign followed by `>`.
- Using the `->` operator, we can write

```
new_node->value = 10;
```

instead of

```
(*new_node).value = 10;
```

## The `->` Operator

- The `->` operator produces an lvalue, so we can use it wherever an ordinary variable would be allowed.
- A `scanf` example:  

```
scanf("%d", &new_node->value);
```
- The `&` operator is still required, even though `new_node` is a pointer.

## Inserting a Node at the Beginning of a Linked List

- One of the advantages of a linked list is that nodes can be added at any point in the list.
- However, the beginning of a list is the easiest place to insert a node.
- Suppose that `new_node` is pointing to the node to be inserted, and `first` is pointing to the first node in the linked list.

## Inserting a Node at the Beginning of a Linked List

- It takes two statements to insert the node into the list.
- The first step is to modify the new node's `next` member to point to the node that was previously at the beginning of the list:

```
new_node->next = first;
```

- The second step is to make `first` point to the new node:

```
first = new_node;
```

- These statements work even if the list is empty.



## Inserting a Node at the Beginning of a Linked List

- Let's trace the process of inserting two nodes into an empty list.
- We'll insert a node containing the number 10 first, followed by a node containing 20.

# Inserting a Node at the Beginning of a Linked List

```
first = NULL;
```

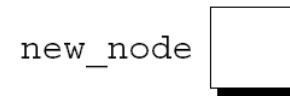

```
new_node =  
    malloc(sizeof(struct node))
```

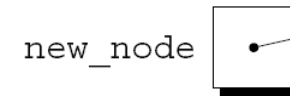

```
new_node->value = 10;
```

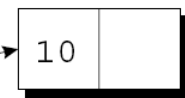
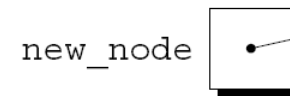

# Inserting a Node at the Beginning of a Linked List

```
new_node->next = first;
```

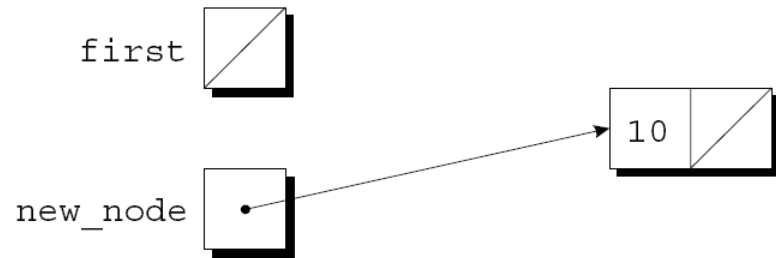

```
first = new_node;
```

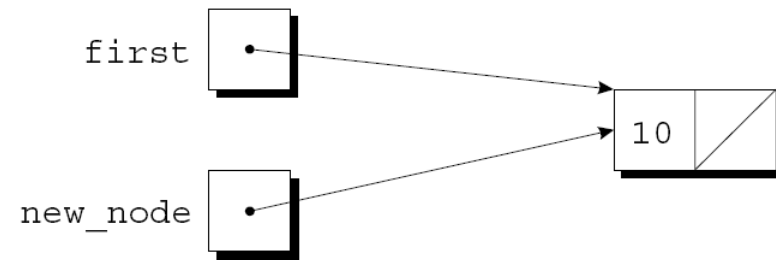

```
new_node =  
    malloc(sizeof(struct node))
```

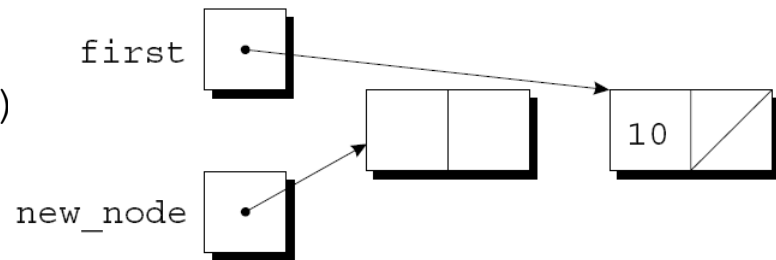

# Inserting a Node at the Beginning of a Linked List

```
new_node->value = 20;
```

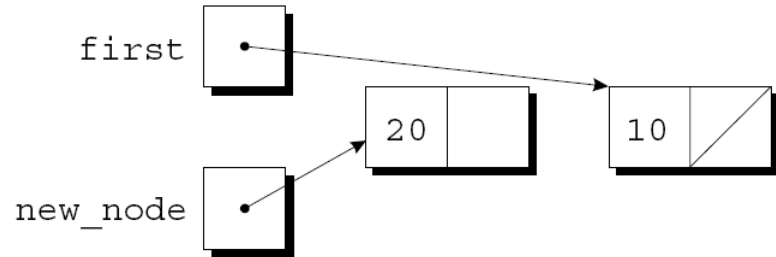

```
new_node->next = first;
```

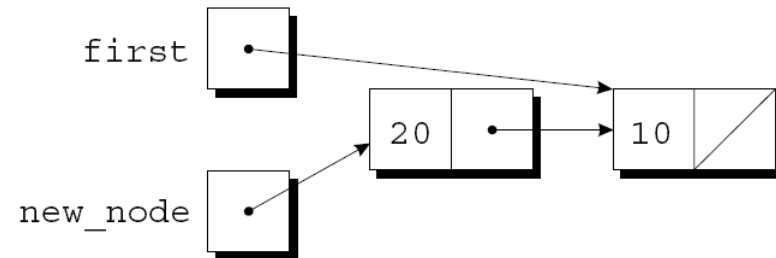

```
first = new_node;
```

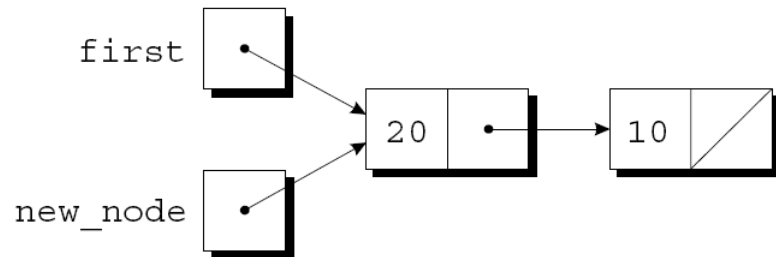

## Inserting a Node at the Beginning of a Linked List

- A function that inserts a node containing  $n$  into a linked list, which pointed to by `list`:

```
struct node *add_to_list(struct node *list, int n)
{
    struct node *new_node;

    new_node = malloc(sizeof(struct node));
    if (new_node == NULL) {
        printf("Error: malloc failed in add_to_list\n");
        exit(EXIT_FAILURE);
    }
    new_node->value = n;
    new_node->next = list;
    return new_node;
}
```

## Inserting a Node at the Beginning of a Linked List

- Note that `add_to_list` returns a pointer to the newly created node (now at the beginning of the list).
- When we call `add_to_list`, we'll need to store its return value into `first`:

```
first = add_to_list(first, 10);  
first = add_to_list(first, 20);
```
- Getting `add_to_list` to update `first` directly, rather than return a new value for `first`, turns out to be tricky.

## Inserting a Node at the Beginning of a Linked List

- A function that uses `add_to_list` to create a linked list containing numbers entered by the user:

```
struct node *read_numbers(void)
{
    struct node *first = NULL;
    int n;

    printf("Enter a series of integers (0 to terminate): ");
    for (;;) {
        scanf("%d", &n);
        if (n == 0)
            return first;
        first = add_to_list(first, n);
    }
}
```

- The numbers will be in reverse order within the list.

## Searching a Linked List

- Although a `while` loop can be used to search a list, the `for` statement is often superior.
- A loop that visits the nodes in a linked list, using a pointer variable `p` to keep track of the “current” node:

```
for (p = first; p != NULL; p = p->next)
    ...
```

- A loop of this form can be used in a function that searches a list for an integer `n`.



## Searching a Linked List

- If it finds *n*, the function will return a pointer to the node containing *n*; otherwise, it will return a null pointer.
- An initial version of the function:

```
struct node *search_list(struct node *list, int n)
{
    struct node *p;

    for (p = list; p != NULL; p = p->next)
        if (p->value == n)
            return p;
    return NULL;
}
```

## Searching a Linked List

- There are many other ways to write `search_list`.
- One alternative is to eliminate the `p` variable, instead using `list` itself to keep track of the current node:

```
struct node *search_list(struct node *list, int n)
{
    for (; list != NULL; list = list->next)
        if (list->value == n)
            return list;
    return NULL;
}
```

- Since `list` is a copy of the original list pointer, there's no harm in changing it within the function.

## Searching a Linked List

- Another alternative:

```
struct node *search_list(struct node *list, int n)
{
    for (; list != NULL && list->value != n;
          list = list->next)
        ;
    return list;
}
```

- Since `list` is `NULL` if we reach the end of the list, returning `list` is correct even if we don't find `n`.

## Searching a Linked List

- This version of `search_list` might be a bit clearer if we used a `while` statement:

```
struct node *search_list(struct node *list, int n)
{
    while (list != NULL && list->value != n)
        list = list->next;
    return list;
}
```

## Deleting a Node from a Linked List

- A big advantage of storing data in a linked list is that we can easily delete nodes.
- Deleting a node involves three steps:
  1. Locate the node to be deleted.
  2. Alter the previous node so that it “bypasses” the deleted node.
  3. Call `free` to reclaim the space occupied by the deleted node.
- Step 1 is harder than it looks, because step 2 requires changing the *previous* node.
- There are various solutions to this problem.

## Deleting a Node from a Linked List

- The “trailing pointer” technique involves keeping a pointer to the previous node (`prev`) as well as a pointer to the current node (`cur`).
- Assume that `list` points to the list to be searched and `n` is the integer to be deleted.
- A loop that implements step 1:

```
for (cur = list, prev = NULL;  
     cur != NULL && cur->value != n;  
     prev = cur, cur = cur->next)  
    ;
```

- When the loop terminates, `cur` points to the node to be deleted and `prev` points to the previous node.

## Deleting a Node from a Linked List

- Assume that `list` has the following appearance and `n` is 20:

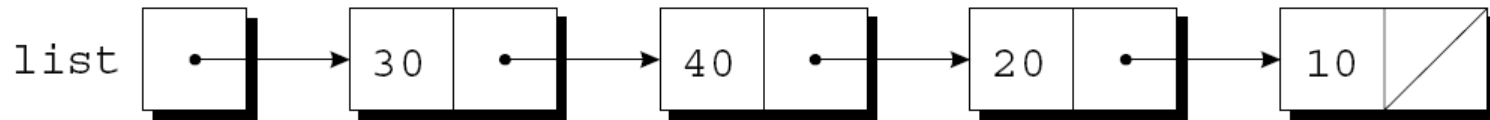

- After `cur = list`, `prev = NULL` has been executed:

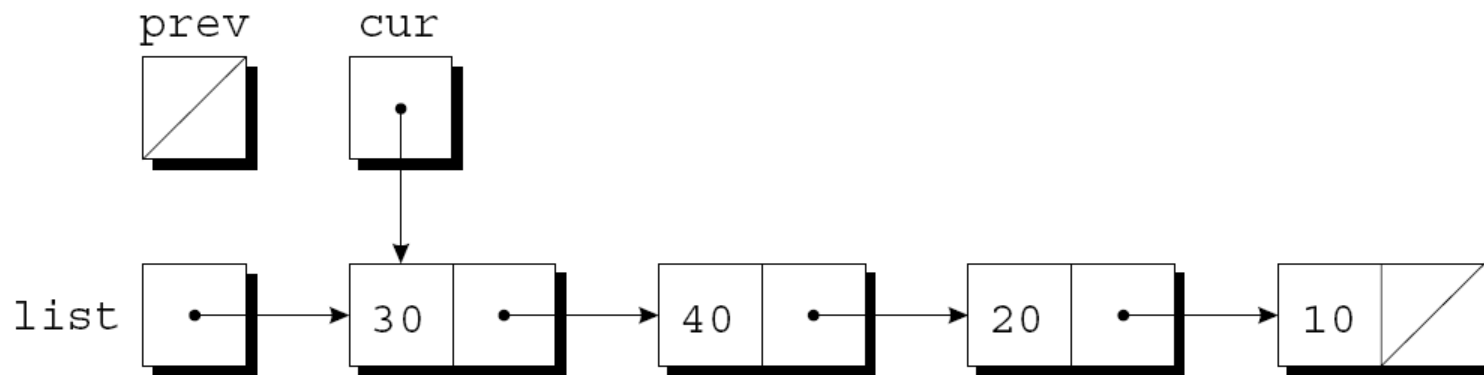

## Deleting a Node from a Linked List

- The test `cur != NULL && cur->value != n` is true, since `cur` is pointing to a node and the node doesn't contain 20.
- After `prev = cur, cur = cur->next` has been executed:

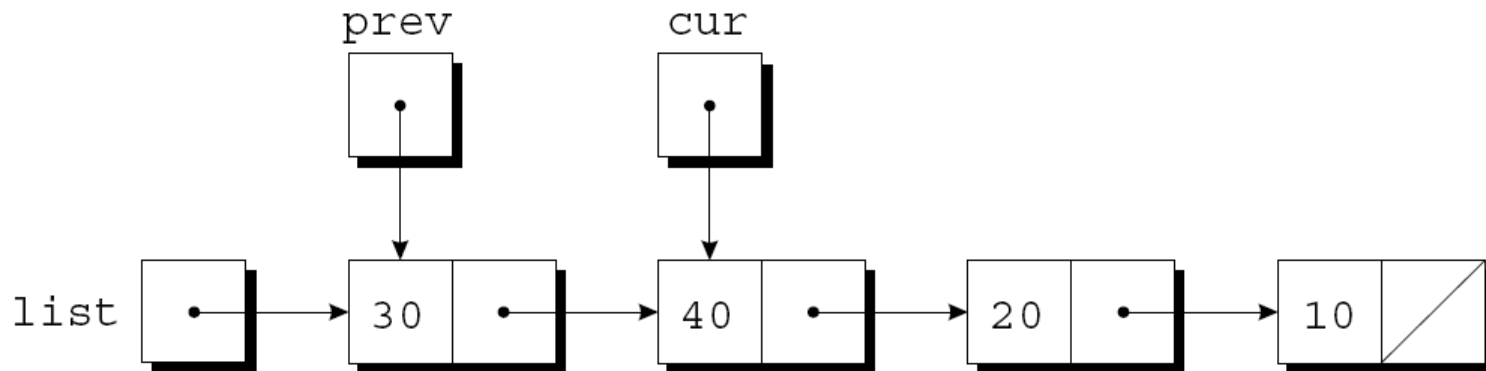



## Deleting a Node from a Linked List

- The test `cur != NULL && cur->value != n` is again true, so `prev = cur, cur = cur->next` is executed once more:

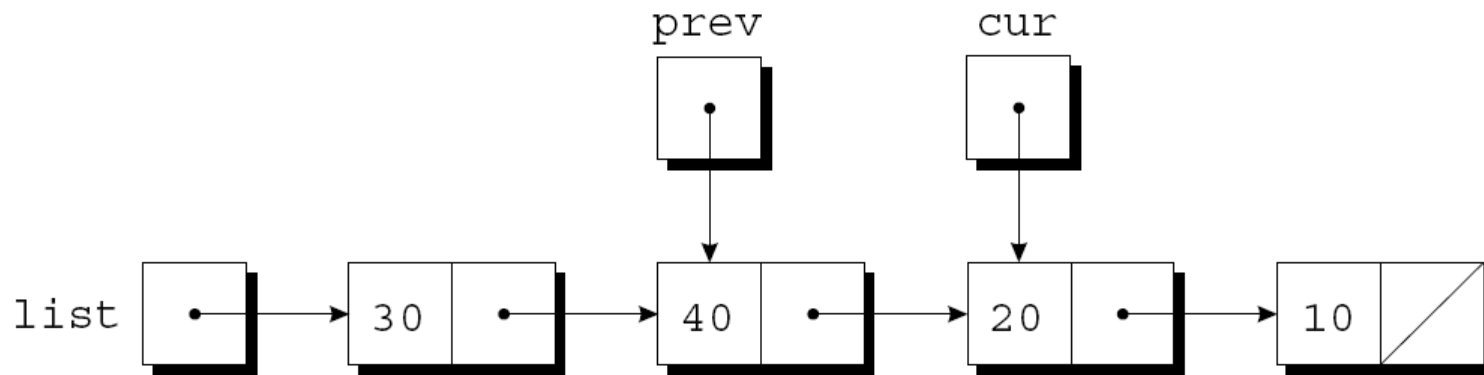

- Since `cur` now points to the node containing 20, the condition `cur->value != n` is false and the loop terminates.

## Deleting a Node from a Linked List

- Next, we'll perform the bypass required by step 2.
- The statement

```
prev->next = cur->next;
```

makes the pointer in the previous node point to the node *after* the current node:

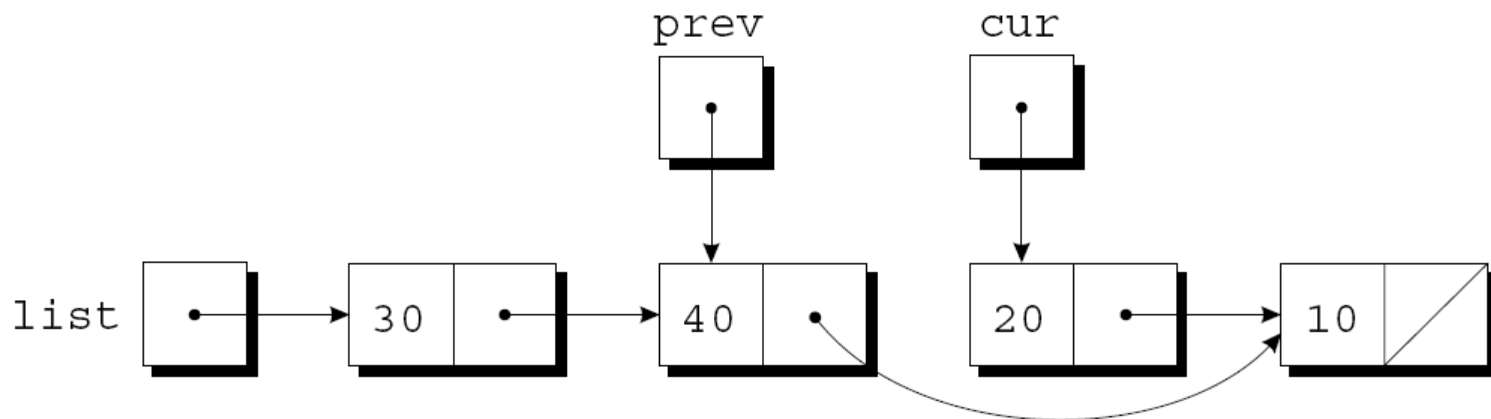

## Deleting a Node from a Linked List

- Step 3 is to release the memory occupied by the current node:

```
free (cur) ;
```

## Deleting a Node from a Linked List

- The `delete_from_list` function uses the strategy just outlined.
- When given a list and an integer `n`, the function deletes the first node containing `n`.
- If no node contains `n`, `delete_from_list` does nothing.
- In either case, the function returns a pointer to the list.
- Deleting the first node in the list is a special case that requires a different bypass step.

## Deleting a Node from a Linked List

```
struct node *delete_from_list(struct node *list, int n)
{
    struct node *cur, *prev;

    for (cur = list, prev = NULL;
         cur != NULL && cur->value != n;
         prev = cur, cur = cur->next)
        ;
    if (cur == NULL)
        return list;           /* n was not found */
    if (prev == NULL)
        list = list->next;     /* n is in the first node */
    else
        prev->next = cur->next; /* n is in some other node */
    free(cur);
    return list;
}
```

## Ordered Lists

- When the nodes of a list are kept in order—sorted by the data stored inside the nodes—we say that the list is *ordered*.
- Inserting a node into an ordered list is more difficult, because the node won't always be put at the beginning of the list.
- However, searching is faster: we can stop looking after reaching the point at which the desired node would have been located.

## Program: Maintaining a Parts Database (Revisited)

- The `inventory2.c` program is a modification of the parts database program of Chapter 16, with the database stored in a linked list this time.
- Advantages of using a linked list:
  - No need to put a limit on the size of the database.
  - Database can easily be kept sorted by part number.
- In the original program, the database wasn't sorted.

## Program: Maintaining a Parts Database (Revisited)

- The `part` structure will contain an additional member (a pointer to the next node):

```
struct part {  
    int number;  
    char name[NAME_LEN+1];  
    int on_hand;  
    struct part *next;  
};
```

- `inventory` will point to the first node in the list:

```
struct part *inventory = NULL;
```



## Program: Maintaining a Parts Database (Revisited)

- Most of the functions in the new program will closely resemble their counterparts in the original program.
- `find_part` and `insert` will be more complex, however, since we'll keep the nodes in the inventory list sorted by part number.

## Program: Maintaining a Parts Database (Revisited)

- In the original program, `find_part` returns an index into the `inventory` array.
- In the new program, `find_part` will return a pointer to the node that contains the desired part number.
- If it doesn't find the part number, `find_part` will return a null pointer.

## Program: Maintaining a Parts Database (Revisited)

- Since the list of parts is sorted, `find_part` can stop when it finds a node containing a part number that's greater than or equal to the desired part number.

- `find_part`'s search loop:

```
for (p = inventory;  
     p != NULL && number > p->number;  
     p = p->next)  
    ;
```

- When the loop terminates, we'll need to test whether the part was found:

```
if (p != NULL && number == p->number)  
    return p;
```

## Program: Maintaining a Parts Database (Revisited)

- The original version of `insert` stores a new part in the next available array element.
- The new version must determine where the new part belongs in the list and insert it there.
- It will also check whether the part number is already present in the list.
- A loop that accomplishes both tasks:

```
for (cur = inventory, prev = NULL;  
     cur != NULL && new_node->number > cur->number;  
     prev = cur, cur = cur->next)  
    ;
```

## Program: Maintaining a Parts Database (Revisited)

- Once the loop terminates, `insert` will check whether `cur` isn't `NULL` and whether `new_node->number` equals `cur->number`.
  - If both are true, the part number is already in the list.
  - Otherwise, `insert` will insert a new node between the nodes pointed to by `prev` and `cur`.
- This strategy works even if the new part number is larger than any in the list.
- Like the original program, this version requires the `read_line` function of Chapter 16.

## Chapter 17: Advanced Uses of Pointers

### inventory2.c

```
/* Maintains a parts database (linked list version) */

#include <stdio.h>
#include <stdlib.h>
#include "readline.h"
#define NAME_LEN 25

struct part {
    int number;
    char name[NAME_LEN+1];
    int on_hand;
    struct part *next;
};

struct part *inventory = NULL;    /* points to first part */

struct part *find_part(int number);
void insert(void);
void search(void);
void update(void);
void print(void);
```

## Chapter 17: Advanced Uses of Pointers

```
/******  
* main: Prompts the user to enter an operation code,      *  
*       then calls a function to perform the requested   *  
*       action. Repeats until the user enters the       *  
*       command 'q'. Prints an error message if the user *  
*       enters an illegal code.                          *  
  
*****  
*/  
int main(void)  
{  
    char code;  
  
    for (;;) {  
        printf("Enter operation code: ");  
        scanf(" %c", &code);  
        while (getchar() != '\n') /* skips to end of line */  
            ;  
    }  
}
```

## Chapter 17: Advanced Uses of Pointers

```
switch (code) {
    case 'i': insert();
               break;
    case 's': search();
               break;
    case 'u': update();
               break;
    case 'p': print();
               break;
    case 'q': return 0;
    default: printf("Illegal code\n");
}
printf("\n");
}
```



## Chapter 17: Advanced Uses of Pointers

```
/******  
 * find_part: Looks up a part number in the inventory      *  
 *             list. Returns a pointer to the node         *  
 *             containing the part number; if the part     *  
 *             number is not found, returns NULL.          *  
*****  
 */  
struct part *find_part(int number)  
{  
    struct part *p;  
  
    for (p = inventory;  
         p != NULL && number > p->number;  
         p = p->next)  
        ;  
    if (p != NULL && number == p->number)  
        return p;  
    return NULL;  
}
```

## Chapter 17: Advanced Uses of Pointers

```
/* ****  
 * insert: Prompts the user for information about a new *  
 * part and then inserts the part into the *  
 * inventory list; the list remains sorted by *  
 * part number. Prints an error message and *  
 * returns prematurely if the part already exists *  
 * or space could not be allocated for the part. *  
 *  
 * ****  
 */  
void insert(void)  
{  
    struct part *cur, *prev, *new_node;  
  
    new_node = malloc(sizeof(struct part));  
    if (new_node == NULL) {  
        printf("Database is full; can't add more parts.\n");  
        return;  
    }  
  
    printf("Enter part number: ");  
    scanf("%d", &code->number);
```

## Chapter 17: Advanced Uses of Pointers

```
for (cur = inventory, prev = NULL;
     cur != NULL && new_node->number > cur->number;
     prev = cur, cur = cur->next)
    ;
if (cur != NULL && new_node->number == cur->number) {
    printf("Part already exists.\n");
    free(new_node);
    return;
}

printf("Enter part name: ");
read_line(new_node->name, NAME_LEN);
printf("Enter quantity on hand: ");
scanf("%d", &new_node->on_hand);

new_node->next = cur;
if (prev == NULL)
    inventory = new_node;
else
    prev->next = new_node;
}
```

## Chapter 17: Advanced Uses of Pointers

```
/******  
 * search: Prompts the user to enter a part number, then *  
 *         looks up the part in the database. If the part *  
 *         exists, prints the name and quantity on hand; *  
 *         if not, prints an error message. *  
*****  
 */  
void search(void)  
{  
    int number;  
    struct part *p;  
  
    printf("Enter part number: ");  
    scanf("%d", &number);  
    p = find_part(number);  
    if (p != NULL) {  
        printf("Part name: %s\n", p->name);  
        printf("Quantity on hand: %d\n", p->on_hand);  
    } else  
        printf("Part not found.\n");  
}
```

## Chapter 17: Advanced Uses of Pointers

```
/*
 * update: Prompts the user to enter a part number.
 * Prints an error message if the part doesn't exist; otherwise, prompts the user to enter change in quantity on hand and updates the database.
 */
void update(void)
{
    int number, change;
    struct part *p;

    printf("Enter part number: ");
    scanf("%d", &number);
    p = find_part(number);
    if (p != NULL) {
        printf("Enter change in quantity on hand: ");
        scanf("%d", &change);
        p->on_hand += change;
    } else
        printf("Part not found.\n");
}
```

## Chapter 17: Advanced Uses of Pointers

```
/******  
 * print: Prints a listing of all parts in the database, *  
 * showing the part number, part name, and *  
 * quantity on hand. Part numbers will appear in *  
 * ascending order. *  
  
*****  
 */  
void print(void)  
{  
    struct part *p;  
    printf("Part Number    Part Name                "  
           "Quantity on Hand\n");  
    for (p = inventory; p != NULL; p = p->next)  
        printf("%7d        %-25s%11d\n", p->number, p->name,  
              p->on_hand);  
}
```

## Pointers to Pointers

- Chapter 13 introduced the idea of a *pointer* to a *pointer*.
- The concept of “pointers to pointers” also pops up frequently in the context of linked data structures.
- In particular, when an argument to a function is a pointer variable, we may want the function to be able to modify the variable.
- Doing so requires the use of a pointer to a pointer.

## Pointers to Pointers

- The `add_to_list` function is passed a pointer to the first node in a list; it returns a pointer to the first node in the updated list:

```
struct node *add_to_list(struct node *list, int n)
{
    struct node *new_node;

    new_node = malloc(sizeof(struct node));
    if (new_node == NULL) {
        printf("Error: malloc failed in add_to_list\n");
        exit(EXIT_FAILURE);
    }
    new_node->value = n;
    new_node->next = list;
    return new_node;
}
```



## Pointers to Pointers

- Modifying `add_to_list` so that it assigns `new_node` to `list` instead of returning `new_node` doesn't work.
- Example:  

```
add_to_list(first, 10);
```
- At the point of the call, `first` is copied into `list`.
- If the function changes the value of `list`, making it point to the new node, `first` is not affected.

## Pointers to Pointers

- Getting `add_to_list` to modify `first` requires passing `add_to_list` a *pointer* to `first`:

```
void add_to_list(struct node **list, int n)
{
    struct node *new_node;

    new_node = malloc(sizeof(struct node));
    if (new_node == NULL) {
        printf("Error: malloc failed in add_to_list\n");
        exit(EXIT_FAILURE);
    }
    new_node->value = n;
    new_node->next = *list;
    *list = new_node;
}
```

## Pointers to Pointers

- When the new version of `add_to_list` is called, the first argument will be the address of `first`:  

```
add_to_list(&first, 10);
```
- Since `list` is assigned the address of `first`, we can use `*list` as an alias for `first`.
- In particular, assigning `new_node` to `*list` will modify `first`.

## Pointers to Functions

- C doesn't require that pointers point only to *data*; it's also possible to have pointers to *functions*.
- Functions occupy memory locations, so every function has an address.
- We can use function pointers in much the same way we use pointers to data.
- Passing a function pointer as an argument is fairly common.

## Function Pointers as Arguments

- A function named `integrate` that integrates a mathematical function `f` can be made as general as possible by passing `f` as an argument.

- Prototype for `integrate` :

```
double integrate(double (*f)(double),  
                double a, double b);
```

The parentheses around `*f` indicate that `f` is a pointer to a function.

- An alternative prototype:

```
double integrate(double f(double),  
                double a, double b);
```

## Function Pointers as Arguments

- A call of `integrate` that integrates the `sin` (sine) function from 0 to  $\pi/2$ :

```
result = integrate(sin, 0.0, PI / 2);
```

- When a function name isn't followed by parentheses, the C compiler produces a pointer to the function.
- Within the body of `integrate`, we can call the function that `f` points to:

```
y = (*f)(x);
```

- Writing `f(x)` instead of `(*f)(x)` is allowed.

## The `qsort` Function

- Some of the most useful functions in the C library require a function pointer as an argument.
- One of these is `qsort`, which belongs to the `<stdlib.h>` header.
- `qsort` is a general-purpose sorting function that's capable of sorting any array.

## The `qsort` Function

- `qsort` must be told how to determine which of two array elements is “smaller.”
- This is done by passing `qsort` a pointer to a *comparison function*.
- When given two pointers `p` and `q` to array elements, the comparison function must return an integer that is:
  - *Negative* if `*p` is “less than” `*q`
  - *Zero* if `*p` is “equal to” `*q`
  - *Positive* if `*p` is “greater than” `*q`



## The `qsort` Function

- Prototype for `qsort`:

```
void qsort(void *base, size_t nmem, size_t size,  
           int (*compar)(const void *, const void *));
```

- `base` must point to the first element in the array (or the first element in the portion to be sorted).
- `nmem` is the number of elements to be sorted.
- `size` is the size of each array element, measured in bytes.
- `compar` is a pointer to the comparison function.

## The `qsort` Function

- When `qsort` is called, it sorts the array into ascending order, calling the comparison function whenever it needs to compare array elements.
- A call of `qsort` that sorts the `inventory` array of Chapter 16:

```
qsort(inventory, num_parts,  
      sizeof(struct part), compare_parts);
```

- `compare_parts` is a function that compares two `part` structures.

## The `qsort` Function

- Writing the `compare_parts` function is tricky.
- `qsort` requires that its parameters have type `void *`, but we can't access the members of a `part` structure through a `void *` pointer.
- To solve the problem, `compare_parts` will assign its parameters, `p` and `q`, to variables of type `struct part *`.

## The `qsort` Function

- A version of `compare_parts` that can be used to sort the `inventory` array into ascending order by part number:

```
int compare_parts(const void *p, const void *q)
{
    const struct part *p1 = p;
    const struct part *q1 = q;

    if (p1->number < q1->number)
        return -1;
    else if (p1->number == q1->number)
        return 0;
    else
        return 1;
}
```

## The `qsort` Function

- Most C programmers would write the function more concisely:

```
int compare_parts(const void *p, const void *q)
{
    if (((struct part *) p)->number <
        ((struct part *) q)->number)
        return -1;
    else if (((struct part *) p)->number ==
            ((struct part *) q)->number)
        return 0;
    else
        return 1;
}
```

## The `qsort` Function

- `compare_parts` can be made even shorter by removing the `if` statements:

```
int compare_parts(const void *p, const void *q)
{
    return ((struct part *) p)->number -
           ((struct part *) q)->number;
}
```

## The `qsort` Function

- A version of `compare_parts` that can be used to sort the `inventory` array by part name instead of part number:

```
int compare_parts(const void *p, const void *q)
{
    return strcmp(((struct part *) p)->name,
                  ((struct part *) q)->name);
}
```

## Other Uses of Function Pointers

- Although function pointers are often used as arguments, that's not all they're good for.
- C treats pointers to functions just like pointers to data.
- They can be stored in variables or used as elements of an array or as members of a structure or union.
- It's even possible for functions to return function pointers.



## Other Uses of Function Pointers

- A variable that can store a pointer to a function with an `int` parameter and a return type of `void`:

```
void (*pf) (int);
```

- If `f` is such a function, we can make `pf` point to `f` in the following way:

```
pf = f;
```

- We can now call `f` by writing either

```
(*pf) (i);
```

or

```
pf (i);
```

## Other Uses of Function Pointers

- An array whose elements are function pointers:

```
void (*file_cmd[]) (void) = {new_cmd,  
                             open_cmd,  
                             close_cmd,  
                             close_all_cmd,  
                             save_cmd,  
                             save_as_cmd,  
                             save_all_cmd,  
                             print_cmd,  
                             exit_cmd  
                             };
```

## Other Uses of Function Pointers

- A call of the function stored in position `n` of the `file_cmd` array:

```
(*file_cmd[n]) (); /* or file_cmd[n] ();  
*/
```

- We could get a similar effect with a `switch` statement, but using an array of function pointers provides more flexibility.

## Program: Tabulating the Trigonometric Functions

- The `tabulate.c` program prints tables showing the values of the `cos`, `sin`, and `tan` functions.
- The program is built around a function named `tabulate` that, when passed a function pointer `f`, prints a table showing the values of `f`.
- `tabulate` uses the `ceil` function.
- When given an argument `x` of `double` type, `ceil` returns the smallest integer that's greater than or equal to `x`.

## Program: Tabulating the Trigonometric Functions

- A session with `tabulate.c`:

```
Enter initial value: 0  
Enter final value: .5  
Enter increment: .1
```

x	cos(x)
-----	-----
0.00000	1.00000
0.10000	0.99500
0.20000	0.98007
0.30000	0.95534
0.40000	0.92106
0.50000	0.87758

## Program: Tabulating the Trigonometric Functions

x	sin(x)
0.00000	0.00000
0.10000	0.09983
0.20000	0.19867
0.30000	0.29552
0.40000	0.38942
0.50000	0.47943

x	tan(x)
0.00000	0.00000
0.10000	0.10033
0.20000	0.20271
0.30000	0.30934
0.40000	0.42279
0.50000	0.54630

## Chapter 17: Advanced Uses of Pointers

### tabulate.c

```
/* Tabulates values of trigonometric functions */

#include <math.h>
#include <stdio.h>

void tabulate(double (*f)(double), double first,
              double last, double incr);

int main(void)
{
    double final, increment, initial;

    printf("Enter initial value: ");
    scanf("%lf", &initial);

    printf("Enter final value: ");
    scanf("%lf", &final);

    printf("Enter increment: ");
    scanf("%lf", &increment);
```

## Chapter 17: Advanced Uses of Pointers

```
printf("\n      x      cos(x) "\n      -----  -----\n");  
tabulate(cos, initial, final, increment);  
  
printf("\n      x      sin(x) "\n      -----  -----\n");  
tabulate(sin, initial, final, increment);  
  
printf("\n      x      tan(x) "\n      -----  -----\n");  
tabulate(tan, initial, final, increment);  
  
return 0;  
}  
  
void tabulate(double (*f)(double), double first,  
             double last, double incr)  
{  
    double x;  
    int i, num_intervals;  
  
    num_intervals = ceil((last - first) / incr);  
    for (i = 0; i <= num_intervals; i++) {  
        x = first + i * incr;  
        printf("%10.5f %10.5f\n", x, (*f)(x));  
    }  
}
```



## Restricted Pointers (C99)

- In C99, the keyword `restrict` may appear in the declaration of a pointer:

```
int * restrict p;
```

`p` is said to be a *restricted pointer*.

- The intent is that if `p` points to an object that is later modified, then that object is not accessed in any way other than through `p`.
- Having more than one way to access an object is often called *aliasing*.

## Restricted Pointers (C99)

- Consider the following code:

```
int * restrict p;  
int * restrict q;  
p = malloc(sizeof(int));
```

- Normally it would be legal to copy `p` into `q` and then modify the integer through `q`:

```
q = p;  
*q = 0; /* causes undefined behavior */
```

- Because `p` is a restricted pointer, the effect of executing the statement `*q = 0;` is undefined.

## Restricted Pointers (C99)

- To illustrate the use of `restrict`, consider the `memcpy` and `memmove` functions.
- The C99 prototype for `memcpy`, which copies bytes from one object (pointed to by `s2`) to another (pointed to by `s1`):

```
void *memcpy(void * restrict s1,  
             const void * restrict s2,  
             size_t n);
```

- The use of `restrict` with both `s1` and `s2` indicates that the objects to which they point shouldn't overlap.

## Restricted Pointers (C99)

- In contrast, `restrict` doesn't appear in the prototype for `memmove`:

```
void *memmove(void *s1, const void *s2,  
              size_t n);
```

- `memmove` is similar to `memcpy`, but is guaranteed to work even if the source and destination overlap.
- Example of using `memmove` to shift the elements of an array:

```
int a[100];  
...  
memmove(&a[0], &a[1], 99 * sizeof(int));
```

## Restricted Pointers (C99)

- Prior to C99, there was no way to document the difference between `memcpy` and `memmove`.
- The prototypes for the two functions were nearly identical:

```
void *memcpy(void *s1, const void *s2,  
             size_t n);  
void *memmove(void *s1, const void *s2,  
              size_t n);
```

- The use of `restrict` in the C99 version of `memcpy`'s prototype is a warning that the `s1` and `s2` objects should not overlap.

## Restricted Pointers (C99)

- `restrict` provides information to the compiler that may enable it to produce more efficient code—a process known as *optimization*.
- The C99 standard guarantees that `restrict` has no effect on the behavior of a program that conforms to the standard.
- Most programmers won't use `restrict` unless they're fine-tuning a program to achieve the best possible performance.

## Flexible Array Members (C99)

- Occasionally, we'll need to define a structure that contains an array of an unknown size.
- For example, we might want a structure that stores the characters in a string together with the string's length:

```
struct vstring {  
    int len;  
    char chars[N];  
};
```

- Using a fixed-length array is undesirable: it limits the length of the string and wastes memory.

## Flexible Array Members (C99)

- C programmers traditionally solve this problem by declaring the length of `chars` to be 1 and then dynamically allocating each string:

```
struct vstring {  
    int len;  
    char chars[1];  
};
```

...

```
struct vstring *str =  
    malloc(sizeof(struct vstring) + n - 1);  
str->len = n;
```

- This technique is known as the “struct hack.”



## Flexible Array Members (C99)

- The struct hack is supported by many compilers.
- Some (including GCC) even allow the `chars` array to have zero length.
- The C89 standard doesn't guarantee that the struct hack will work, but a C99 feature known as the *flexible array member* serves the same purpose.

## Flexible Array Members (C99)

- When the last member of a structure is an array, its length may be omitted:

```
struct vstring {  
    int len;  
    char chars[]; /* flexible array member - C99 only */  
};
```

- The length of the array isn't determined until memory is allocated for a `vstring` structure:

```
struct vstring *str =  
    malloc(sizeof(struct vstring) + n);  
str->len = n;
```

`sizeof` ignores the `chars` member when computing the size of the structure.

## Flexible Array Members (C99)

- Special rules for structures that contain a flexible array member:
  - The flexible array must be the last member.
  - The structure must have at least one other member.
- Copying a structure that contains a flexible array member will copy the other members but not the flexible array itself.

## Flexible Array Members (C99)

- A structure that contains a flexible array member is an *incomplete type*.
- An incomplete type is missing part of the information needed to determine how much memory it requires.
- Incomplete types are subject to various restrictions.
- In particular, an incomplete type can't be a member of another structure or an element of an array.
- However, an array may contain pointers to structures that have a flexible array member.