

**William Stallings  
Computer Organization  
and Architecture  
10<sup>th</sup> Edition**

© 2016 Pearson Education, Inc., Hoboken,  
NJ. All rights reserved.

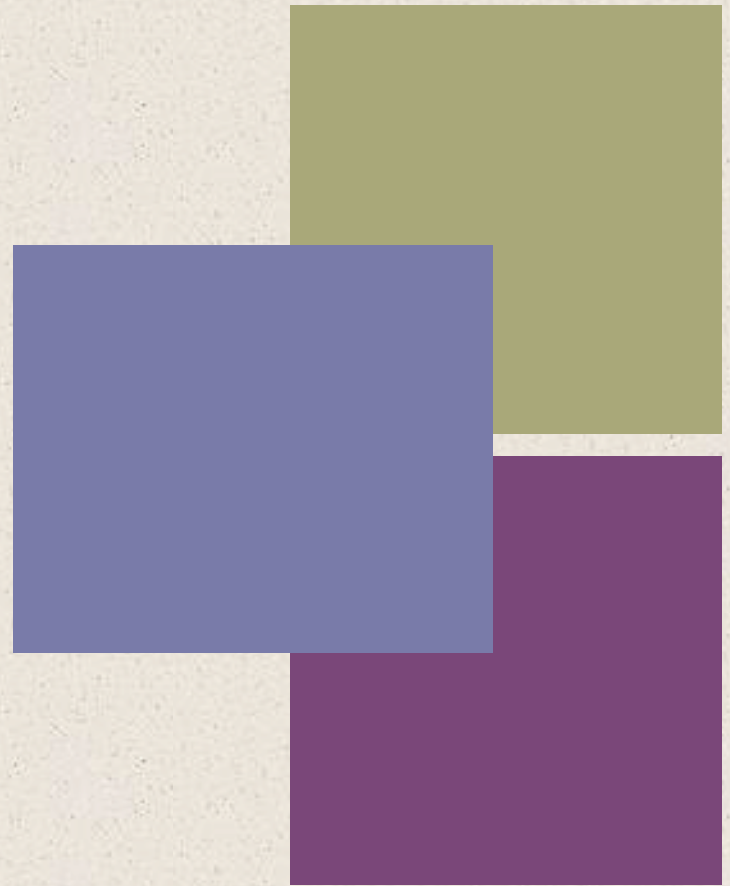

# Chapter 1

+

## Basic Concepts and Computer Evolution

# Computer Architecture

## Computer Organization

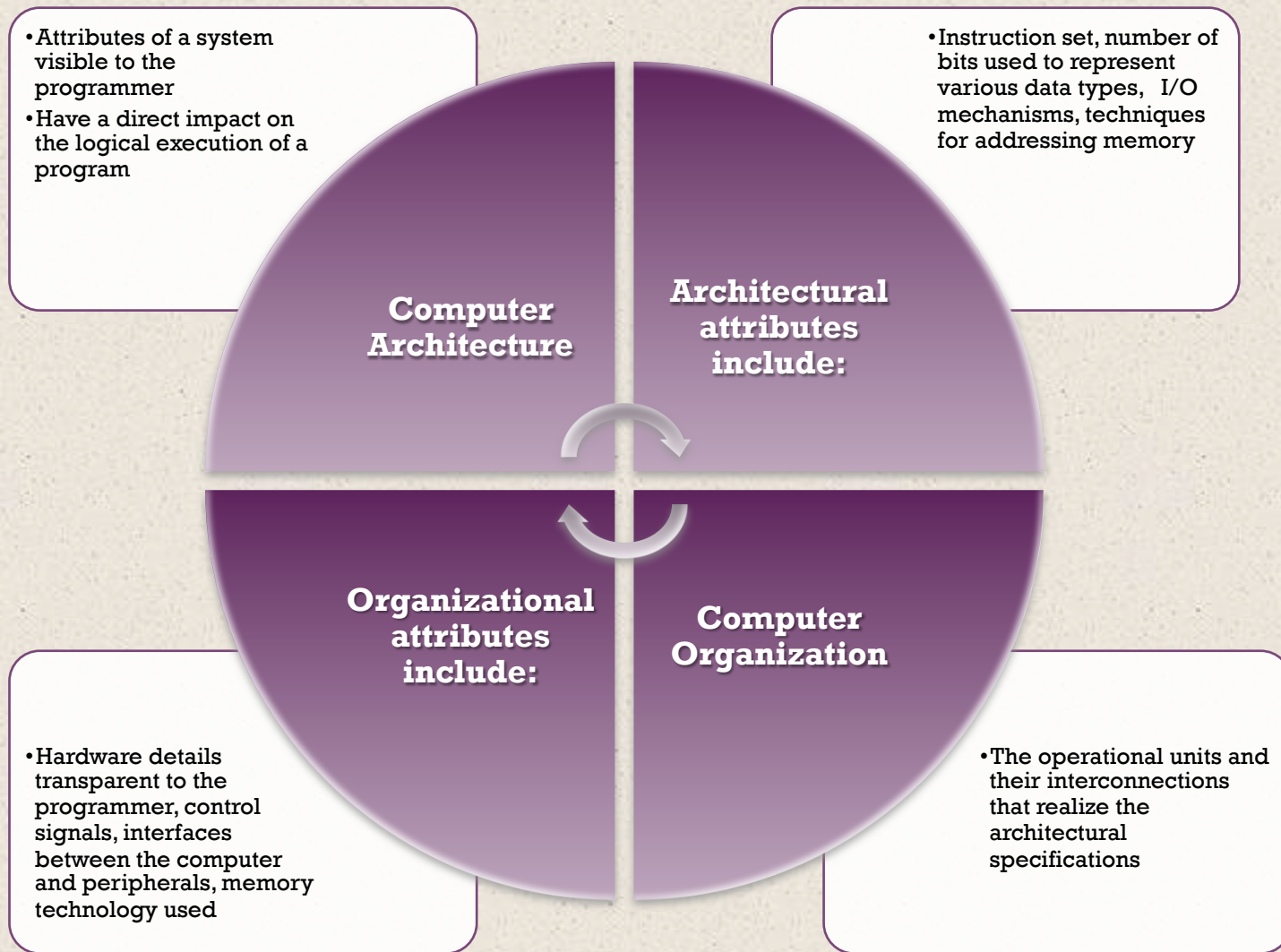

# + IBM System 370 Architecture

- IBM System/370 architecture
  - Was introduced in 1970
  - Included a number of models
  - Could upgrade to a more expensive, faster model without having to abandon original software
  - New models are introduced with improved technology, but retain the same architecture so that the customer's software investment is protected
  - Architecture has survived to this day as the architecture of IBM's mainframe product line





# + Structure and Function

- Hierarchical system
  - Set of interrelated subsystems
- Hierarchical nature of complex systems is essential to both their design and their description
- Designer need only deal with a particular level of the system at a time
  - Concerned with structure and function at each level
- Structure
  - The way in which components relate to each other
- Function
  - The operation of individual components as part of the structure



# + Function

---

- There are four basic functions that a computer can perform:
  - Data processing
    - Data may take a wide variety of forms and the range of processing requirements is broad
  - Data storage
    - Short-term
    - Long-term
  - Data movement
    - Input-output (I/O) - when data are received from or delivered to a device (peripheral) that is directly connected to the computer
    - Data communications – when data are moved over longer distances, to or from a remote device
  - Control
    - A control unit manages the computer's resources and orchestrates the performance of its functional parts in response to instructions

# Structure

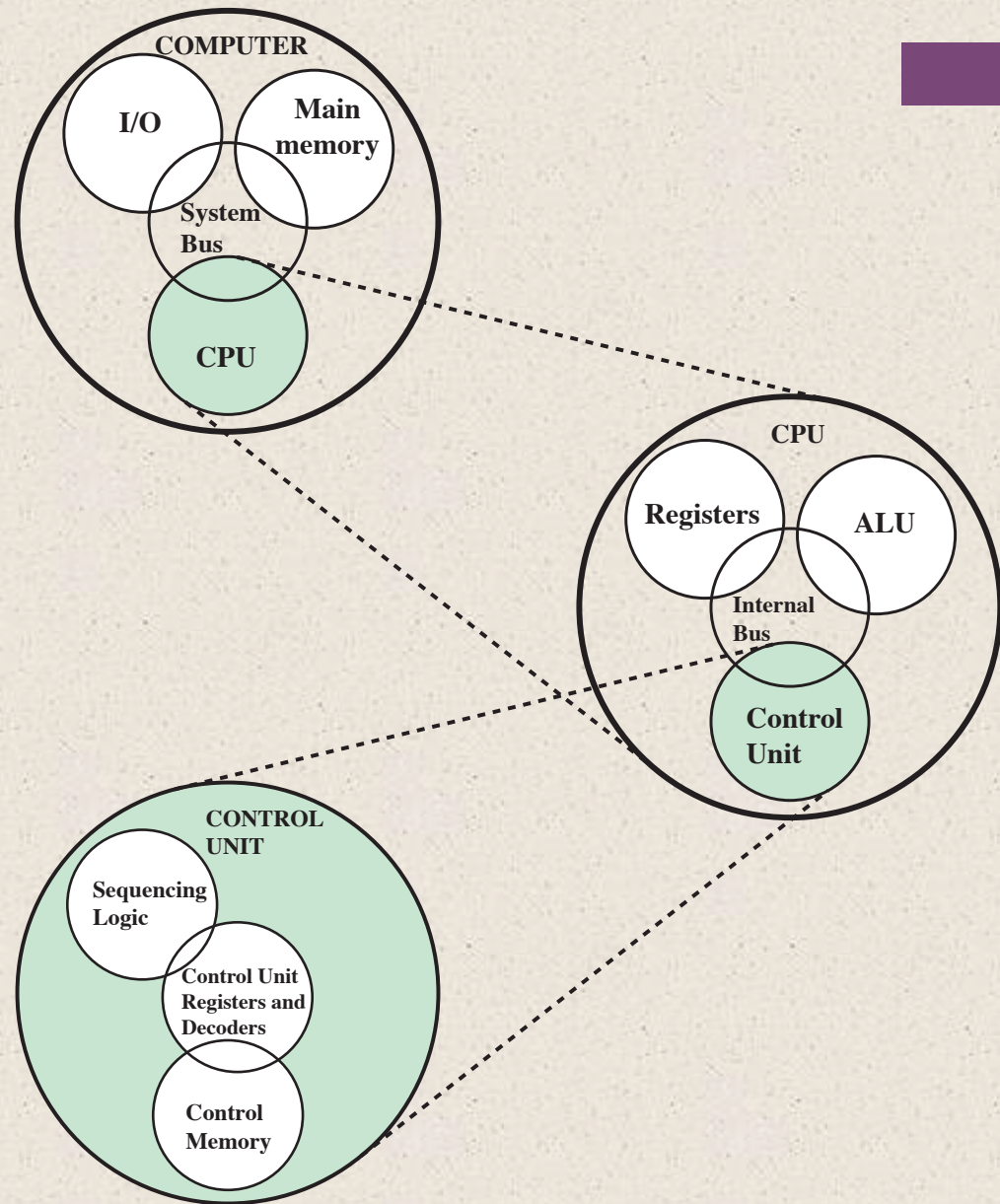

**Figure 1.1 A Top-Down View of a Computer**



There are four main structural components of the computer:

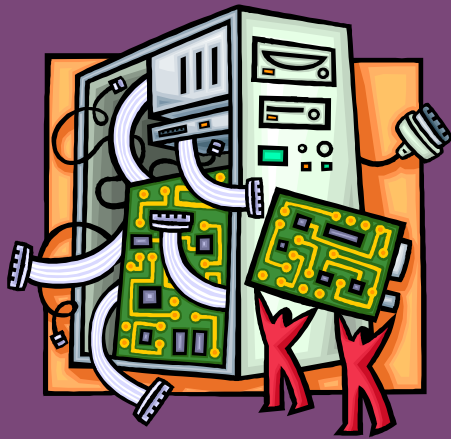

- ★ CPU – controls the operation of the computer and performs its data processing functions
- ★ Main Memory – stores data
- ★ I/O – moves data between the computer and its external environment
- ★ System Interconnection – some mechanism that provides for communication among CPU, main memory, and I/O





# CPU

## Major structural components:

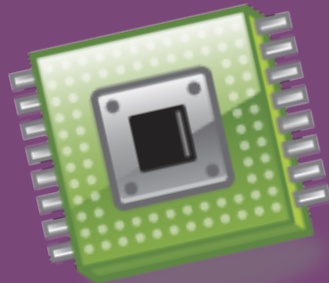
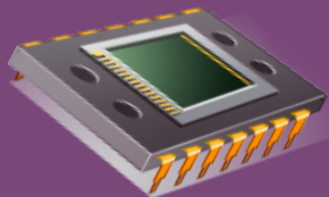

- **Control Unit**
  - Controls the operation of the CPU and hence the computer
- **Arithmetic and Logic Unit (ALU)**
  - Performs the computer's data processing function
- **Registers**
  - Provide storage internal to the CPU
- **CPU Interconnection**
  - Some mechanism that provides for communication among the control unit, ALU, and registers

# + Multicore Computer Structure

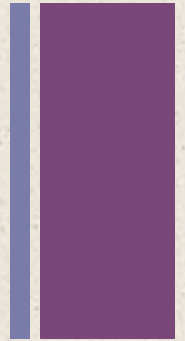

- Central processing unit (CPU)
  - Portion of the computer that fetches and executes instructions
  - Consists of an ALU, a control unit, and registers
  - Referred to as a processor in a system with a single processing unit
- Core
  - An individual processing unit on a processor chip
  - May be equivalent in functionality to a CPU on a single-CPU system
  - Specialized processing units are also referred to as cores
- Processor
  - A physical piece of silicon containing one or more cores
  - Is the computer component that interprets and executes instructions
  - Referred to as a *multicore processor* if it contains multiple cores

# + Cache Memory

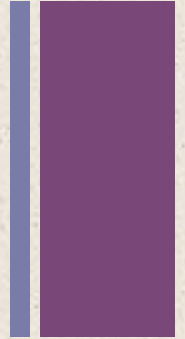

- Multiple layers of memory between the processor and main memory
- Is smaller and faster than main memory
- Used to speed up memory access by placing in the cache data from main memory that is likely to be used in the near future
- A greater performance improvement may be obtained by using multiple levels of cache, with level 1 (L1) closest to the core and additional levels (L2, L3, etc.) progressively farther from the core

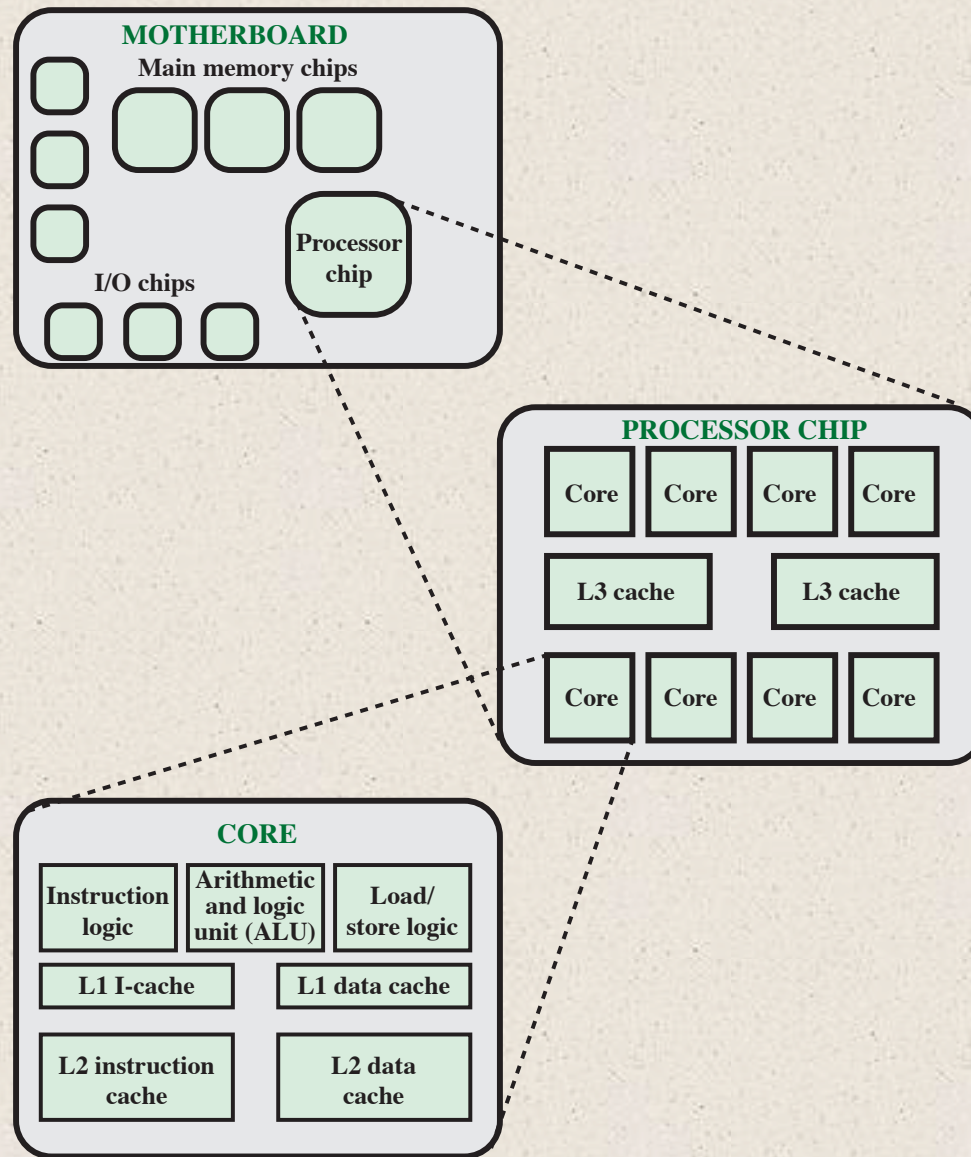

**Figure 1.2 Simplified View of Major Elements of a Multicore Computer**



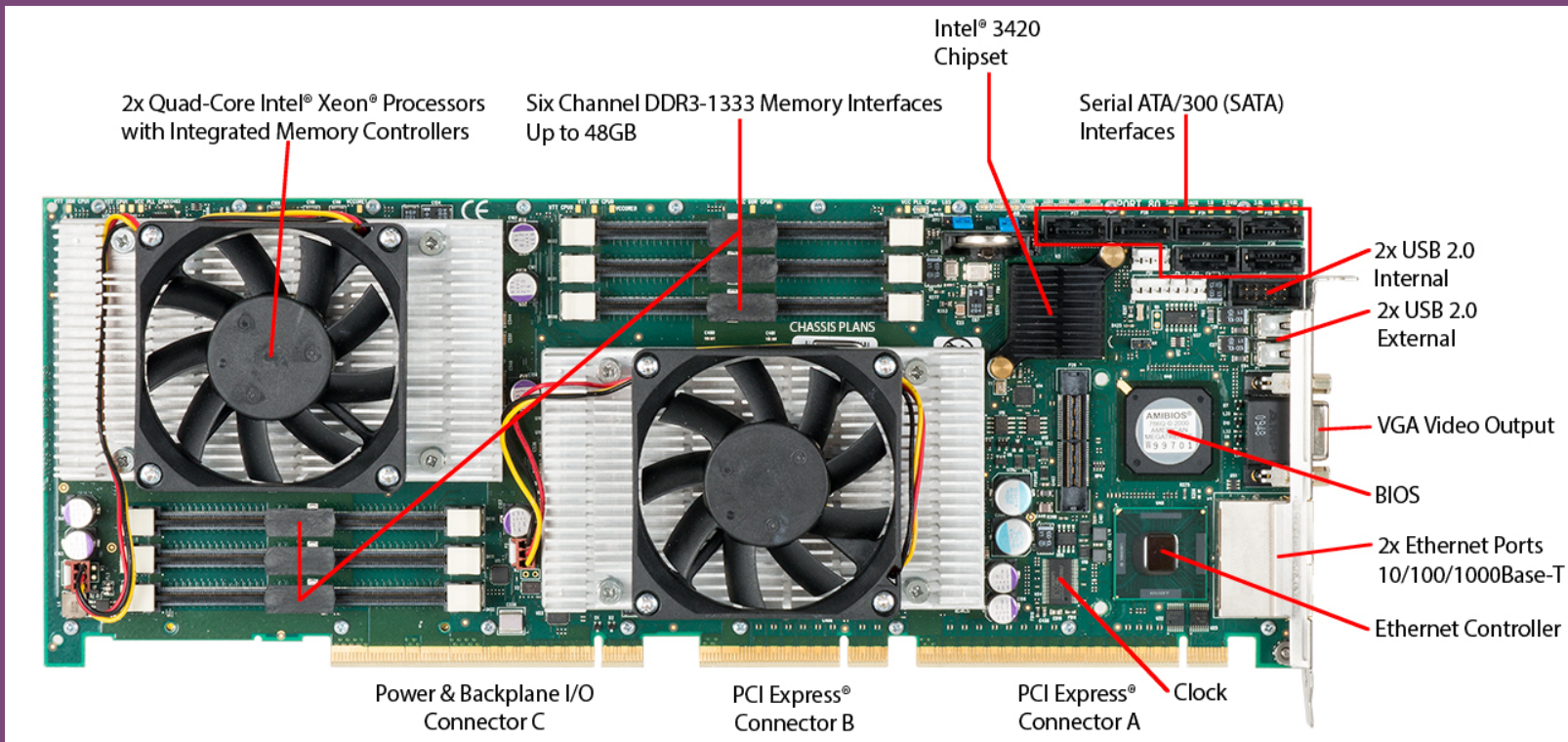

**Figure 1.3**  
Motherboard with Two Intel Quad-Core Xeon Processors



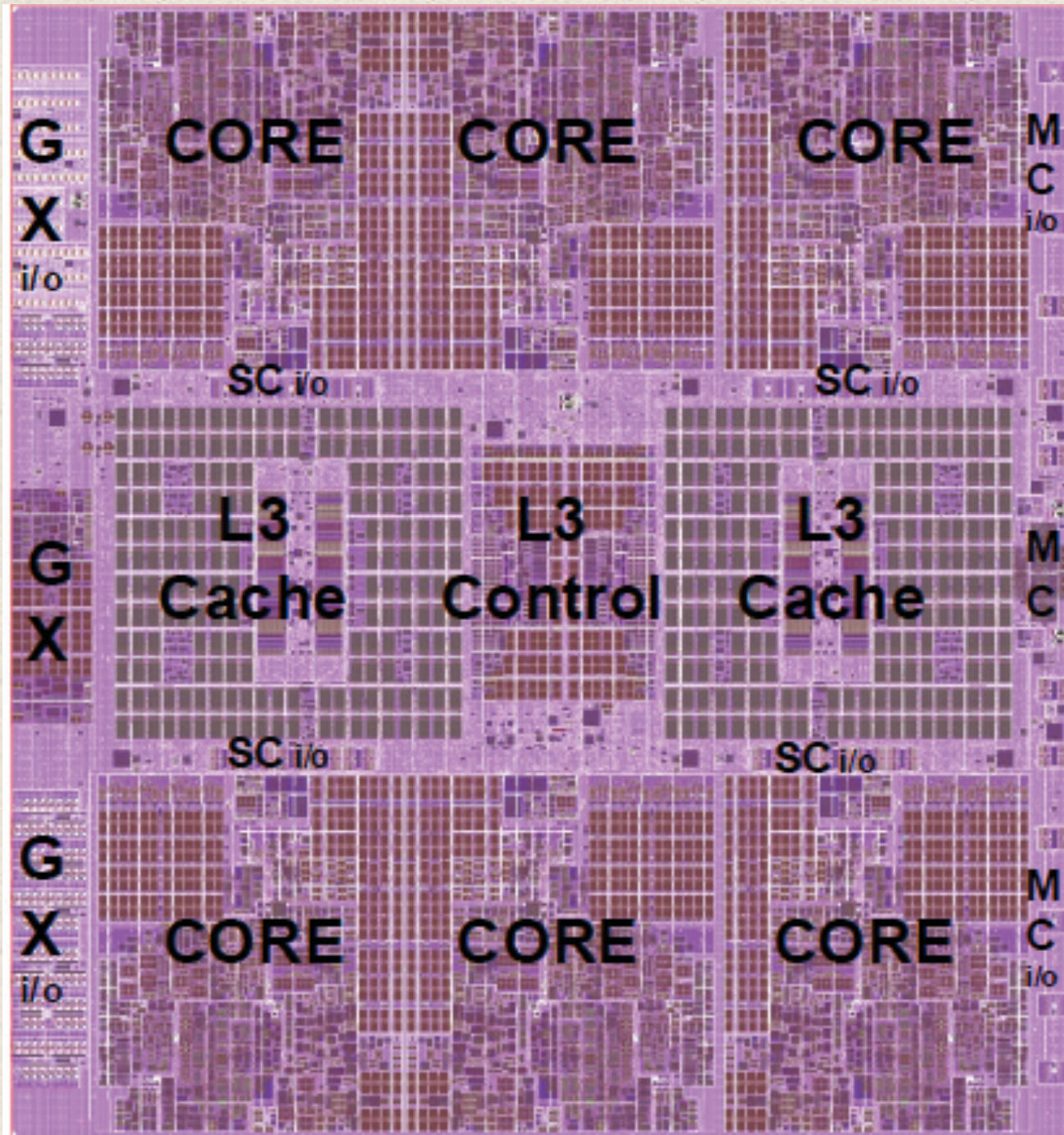

Figure 1.4

zEnterprise  
EC12 Processor  
Unit (PU)  
Chip Diagram



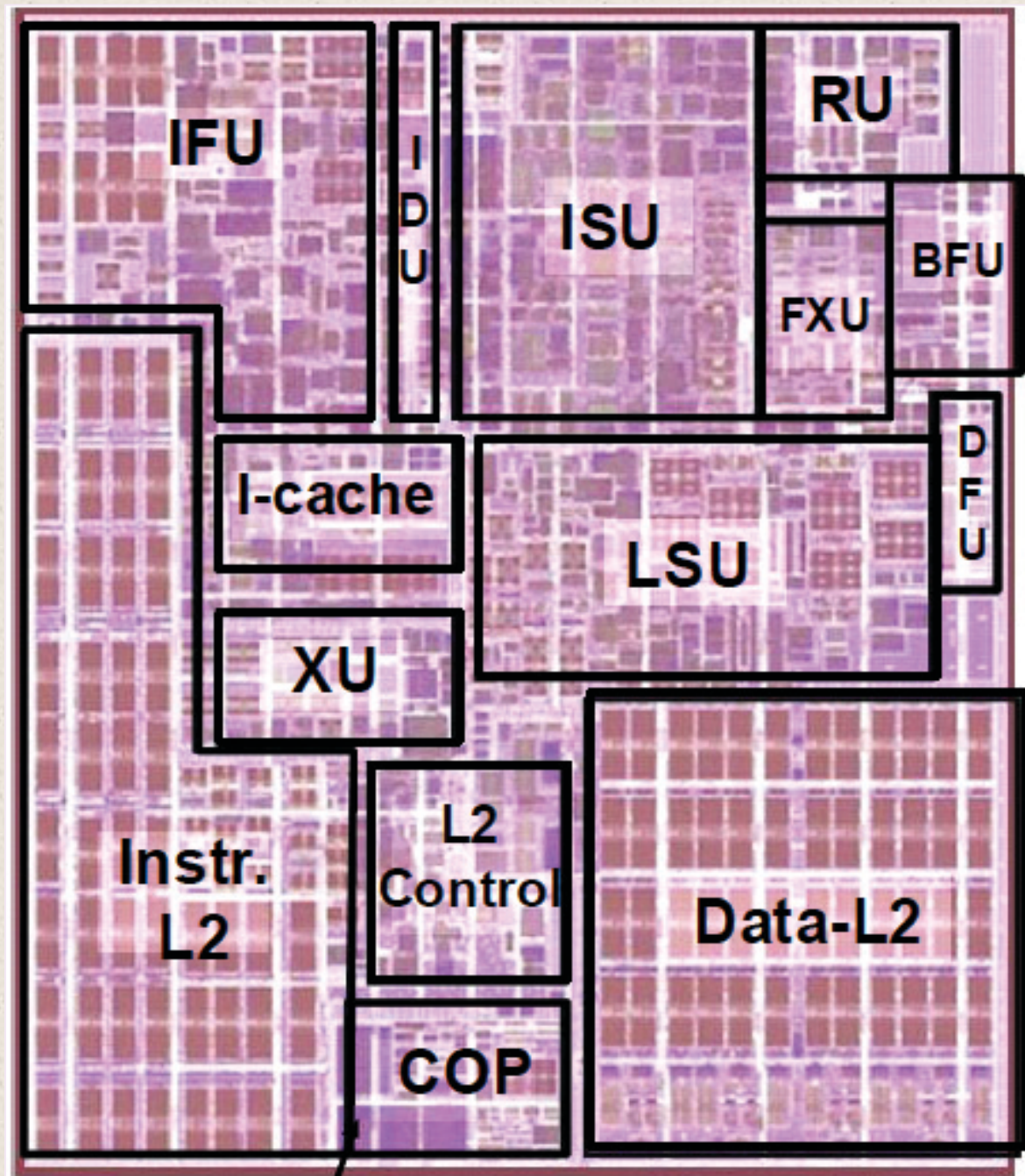
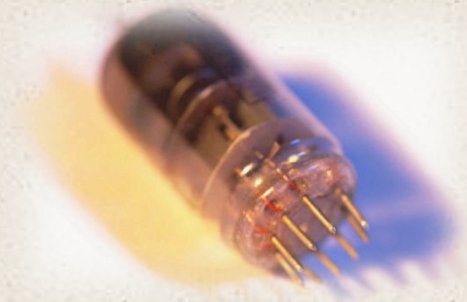

Figure 1.5  
zEnterprise  
EC12  
Core Layout

# + History of Computers

## First Generation: Vacuum Tubes

- Vacuum tubes were used for digital logic elements and memory
- IAS computer
  - Fundamental design approach was the stored program concept
    - Attributed to the mathematician John von Neumann
    - First publication of the idea was in 1945 for the EDVAC
  - Design began at the Princeton Institute for Advanced Studies
  - Completed in 1952
  - Prototype of all subsequent general-purpose computers





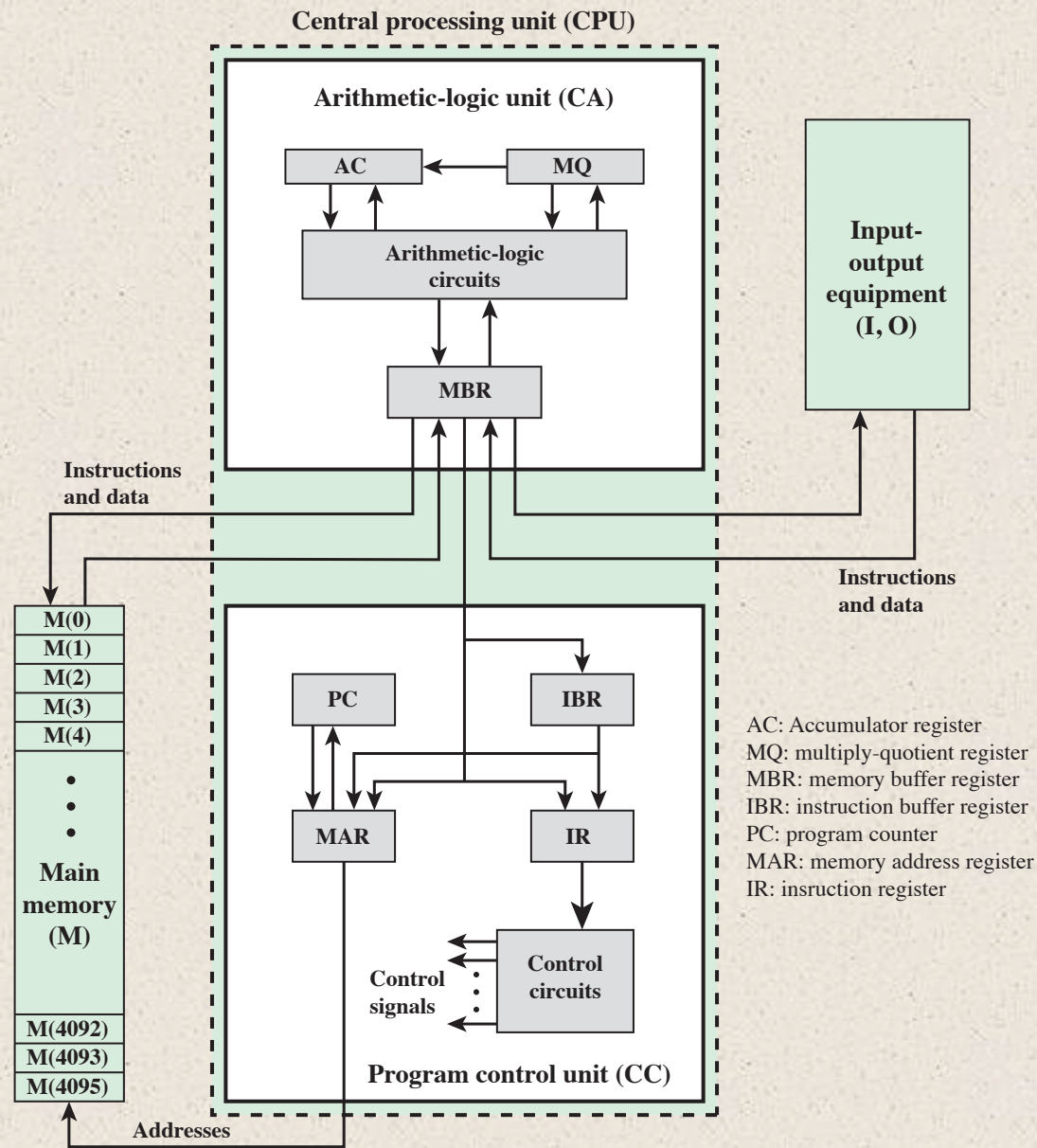

**Figure 1.6 IAS Structure**

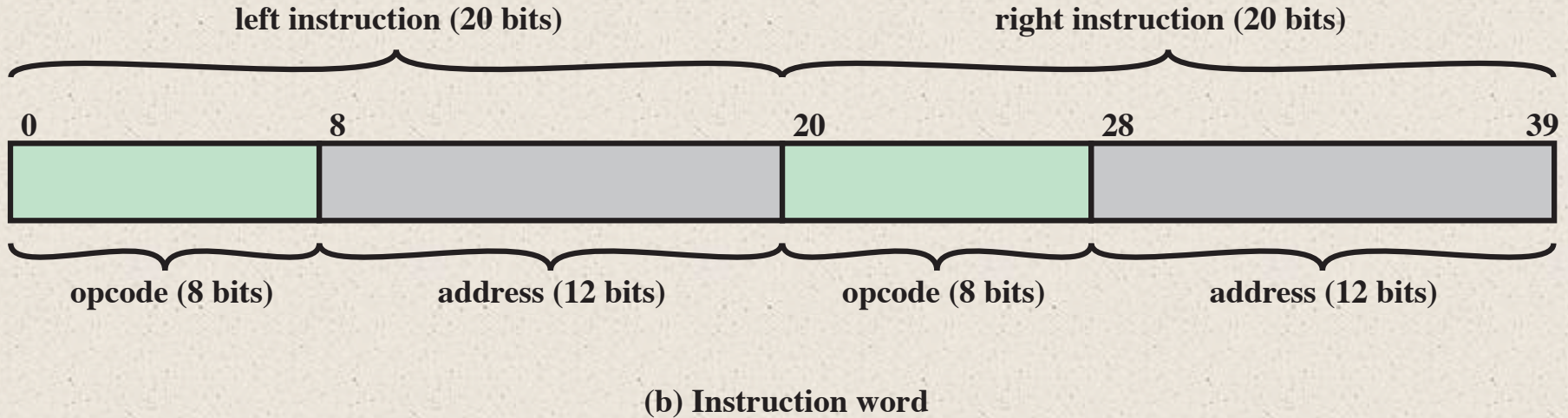
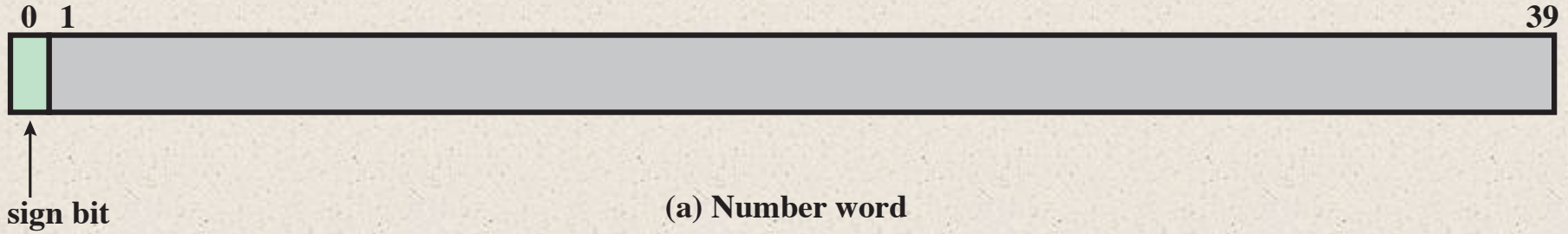

**Figure 1.7 IAS Memory Formats**



# Registers

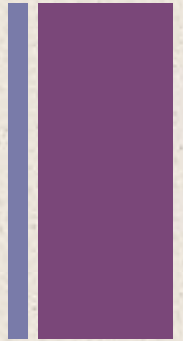

## Memory buffer register (MBR)

- Contains a word to be stored in memory or sent to the I/O unit
- Or is used to receive a word from memory or from the I/O unit

## Memory address register (MAR)

- Specifies the address in memory of the word to be written from or read into the MBR

## Instruction register (IR)

- Contains the 8-bit opcode instruction being executed

## Instruction buffer register (IBR)

- Employed to temporarily hold the right-hand instruction from a word in memory

## Program counter (PC)

- Contains the address of the next instruction pair to be fetched from memory

## Accumulator (AC) and multiplier quotient (MQ)

- Employed to temporarily hold operands and results of ALU operations

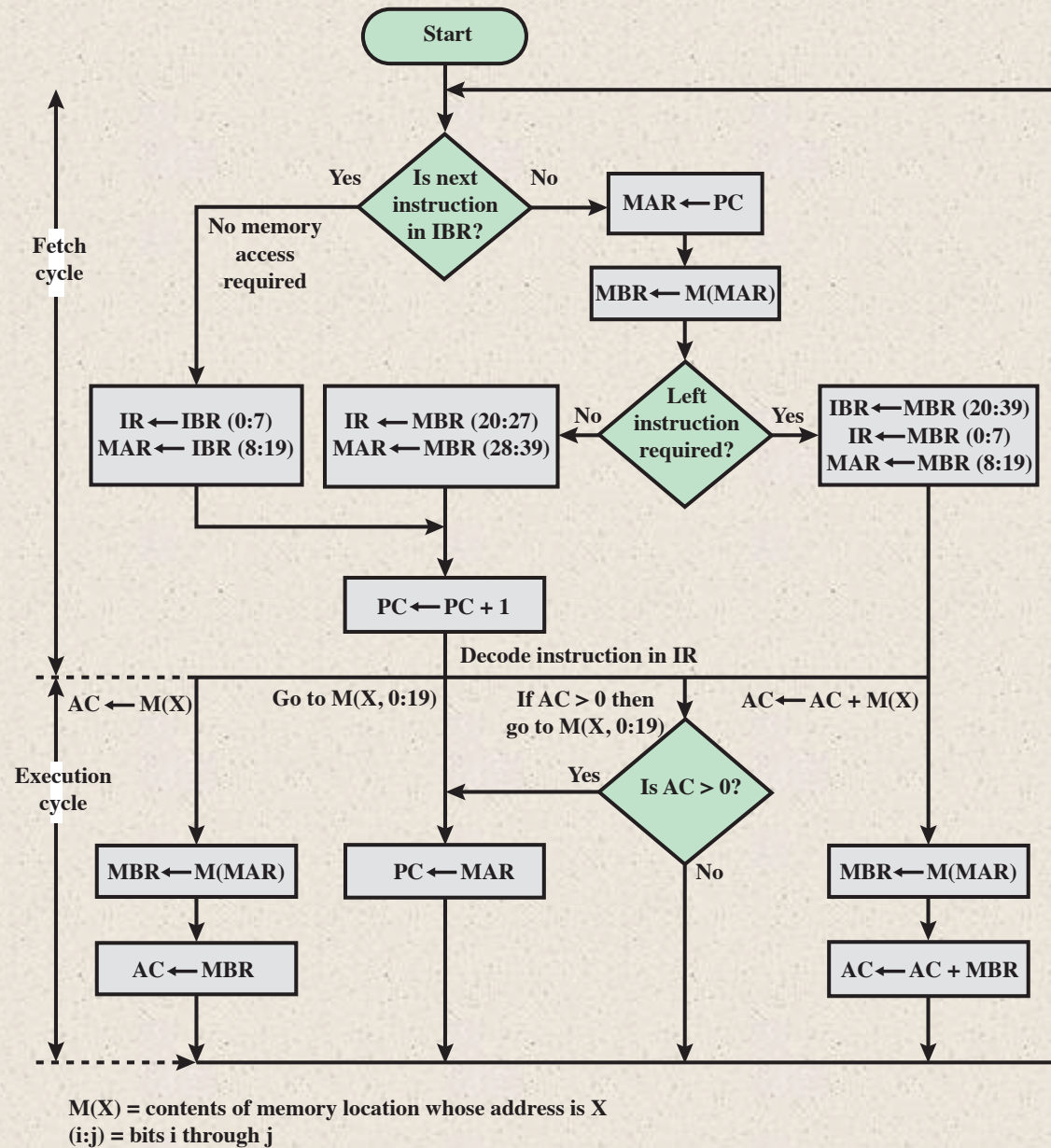

Figure 1.8 Partial Flowchart of IAS Operation



| Instruction Type     | Opcode   | Symbolic Representation  | Description   |
|----------------------|----------|--|---|
| Data transfer        | 00001010 | LOAD MQ  | Transfer contents of register MQ to the accumulator AC  |
|                      | 00001001 | LOAD MQ,M(X)   | Transfer contents of memory location X to MQ  |
|                      | 00100001 | STOR M(X)  | Transfer contents of accumulator to memory location X   |
|                      | 00000001 | LOAD M(X)  | Transfer M(X) to the accumulator  |
|                      | 00000010 | LOAD -M(X)   | Transfer -M(X) to the accumulator   |
|                      | 00000011 | LOAD  M(X)   | Transfer absolute value of M(X) to the accumulator  |
|                      | 00000100 | LOAD - M(X)  | Transfer - M(X)  to the accumulator   |
| Unconditional branch | 00001101 | JUMP M(X,0:19)   | Take next instruction from left half of M(X)  |
|                      | 00001110 | JUMP M(X,20:39)  | Take next instruction from right half of M(X)   |
| Conditional branch   | 00001111 | JUMP+ M(X,0:19)  | If number in the accumulator is nonnegative, take next instruction from left half of M(X)         |
|                      |          | <i>JU</i><br><i>MP</i><br>+<br><i>M(X</i><br><i>,20:</i><br><i>39)</i> | <i>If number in the accumulator is nonnegative, take next instruction from right half of M(X)</i> |
| Arithmetic           | 00000101 | ADD M(X)   | Add M(X) to AC; put the result in AC  |
|                      | 00000111 | ADD  M(X)  | Add  M(X)  to AC; put the result in AC  |
|                      | 00000110 | SUB M(X)   | Subtract M(X) from AC; put the result in AC   |
|                      | 00001000 | SUB  M(X)  | Subtract  M(X)  from AC; put the remainder in AC  |
|                      | 00001011 | MUL M(X)   | Multiply M(X) by MQ; put most significant bits of result in AC, put least significant bits in MQ  |
|                      | 00001100 | DIV M(X)   | Divide AC by M(X); put the quotient in MQ and the remainder in AC                                 |
|                      | 00010100 | LSH  | Multiply accumulator by 2; i.e., shift left one bit position                                      |
|                      | 00010101 | RSH  | Divide accumulator by 2; i.e., shift right one position   |
| Address modify       | 00010010 | STOR M(X,8:19)   | Replace left address field at M(X) by 12 rightmost bits of AC                                     |
|                      | 00010011 | STOR M(X,28:39)  | Replace right address field at M(X) by 12 rightmost bits of AC                                    |

**Table 1.1**

**The IAS**

**Instruction Set**

(Table can be found on page 17 in the textbook.)



# History of Computers

## Second Generation: Transistors

- Smaller
- Cheaper
- Dissipates less heat than a vacuum tube
- Is a *solid state device* made from silicon
- Was invented at Bell Labs in 1947
- It was not until the late 1950's that fully transistorized computers were commercially available

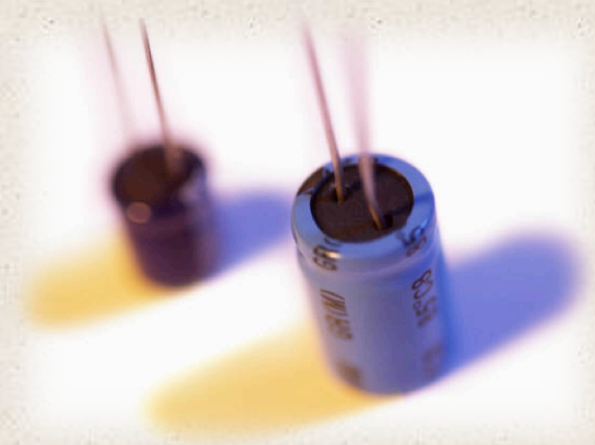



# Table 1.2

## Computer Generations

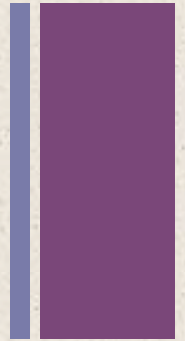

| <b>Generation</b> | <b>Approximate Dates</b> | <b>Technology</b>                  | <b>Typical Speed (operations per second)</b> |
|-------------------|--------------------------|------------------------------------|--|
| 1                 | 1946–1957                | Vacuum tube                        | 40,000                                       |
| 2                 | 1957–1964                | Transistor                         | 200,000                                      |
| 3                 | 1965–1971                | Small and medium scale integration | 1,000,000                                    |
| 4                 | 1972–1977                | Large scale integration            | 10,000,000                                   |
| 5                 | 1978–1991                | Very large scale integration       | 100,000,000                                  |
| 6                 | 1991-                    | Ultra large scale integration      | >1,000,000,000                               |



# Second Generation Computers

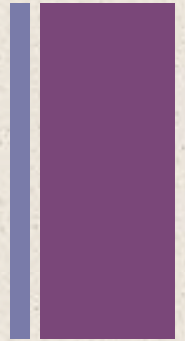

## ■ Introduced:

- More complex arithmetic and logic units and control units
- The use of high-level programming languages
- Provision of *system software* which provided the ability to:
  - Load programs
  - Move data to peripherals
  - Libraries perform common computations

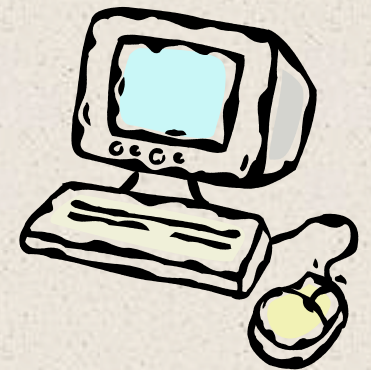



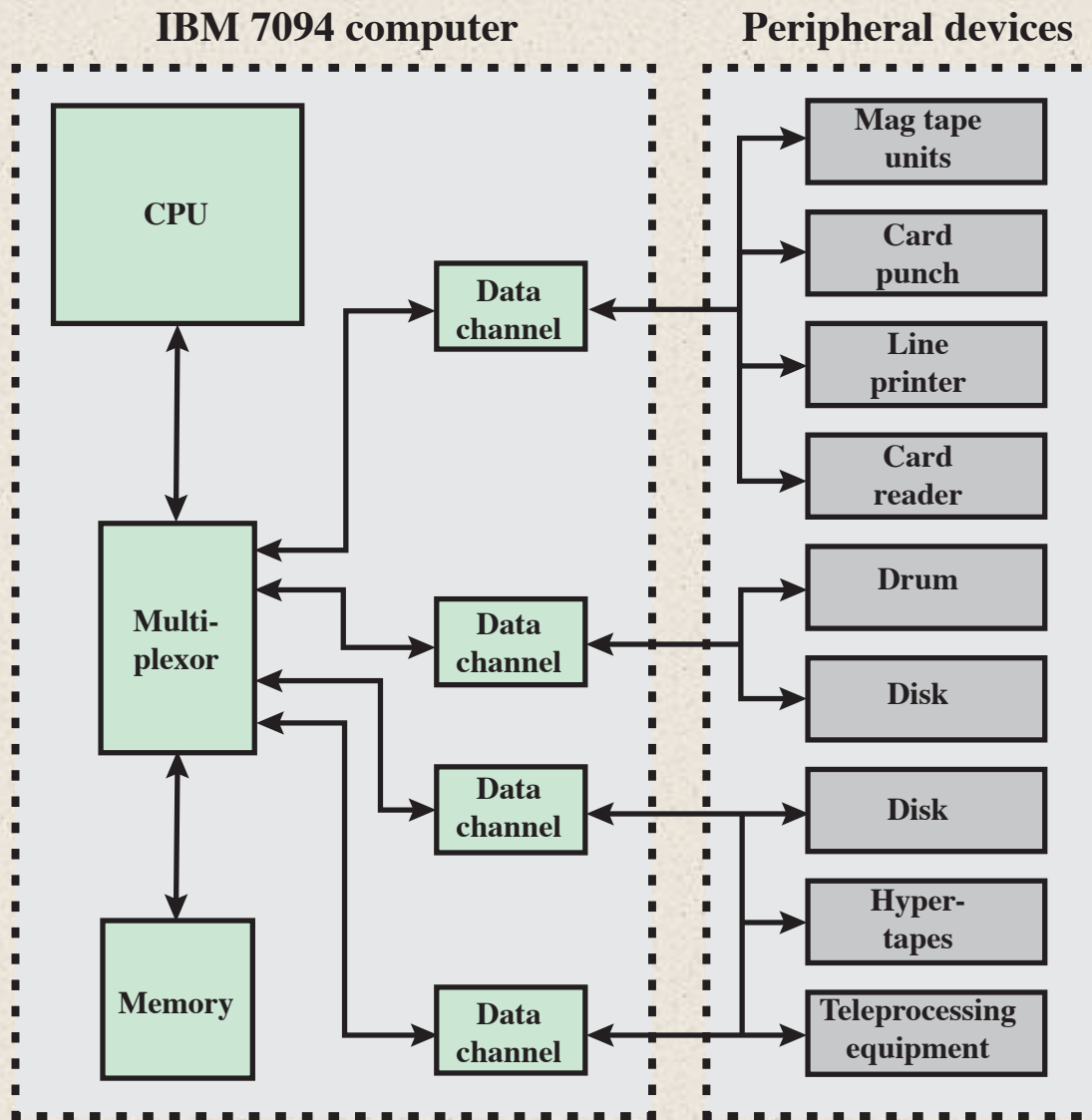

**Figure 1.9 An IBM 7094 Configuration**

# History of Computers

## Third Generation: Integrated Circuits



- 1958 – the invention of the integrated circuit
- *Discrete component*
  - Single, self-contained transistor
  - Manufactured separately, packaged in their own containers, and soldered or wired together onto masonite-like circuit boards
  - Manufacturing process was expensive and cumbersome
- The two most important members of the third generation were the IBM System/360 and the DEC PDP-8

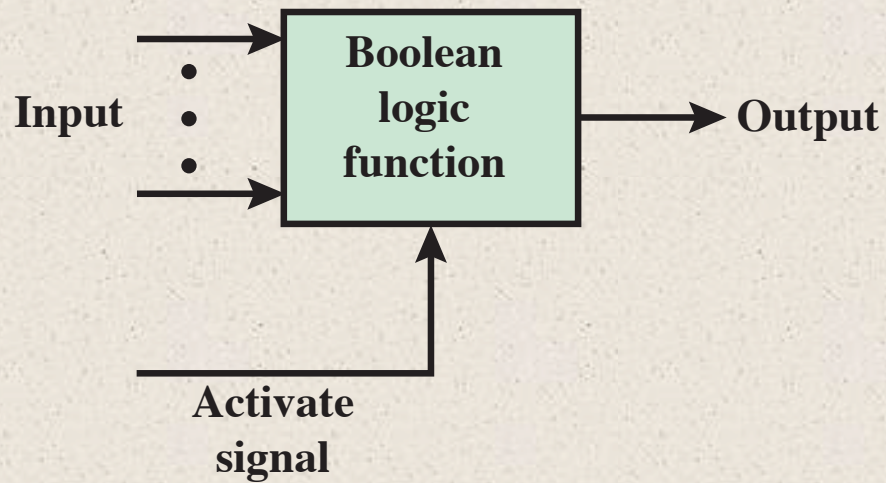

(a) Gate

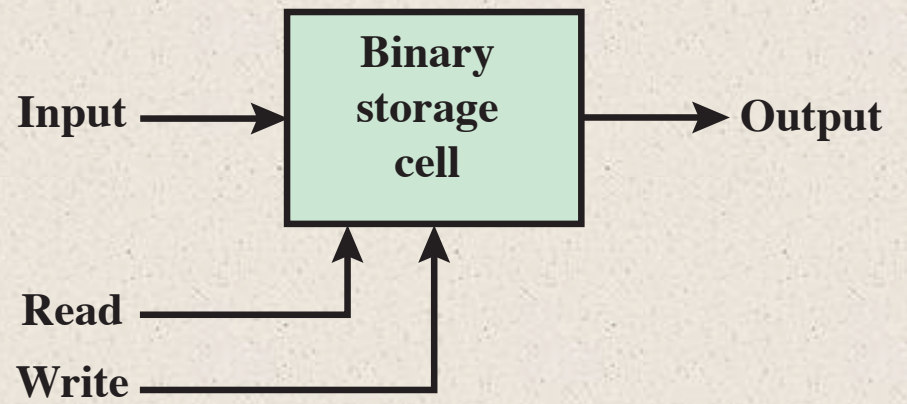

(b) Memory cell

**Figure 1.10 Fundamental Computer Elements**



# Integrated Circuits

- Data storage – provided by memory cells
  - Data processing – provided by gates
  - Data movement – the paths among components are used to move data from memory to memory and from memory through gates to memory
  - Control – the paths among components can carry control signals
- A computer consists of gates, memory cells, and interconnections among these elements
  - The gates and memory cells are constructed of simple digital electronic components
  - Exploits the fact that such components as transistors, resistors, and conductors can be fabricated from a semiconductor such as silicon
  - Many transistors can be produced at the same time on a single wafer of silicon
  - Transistors can be connected with a processor metallization to form circuits





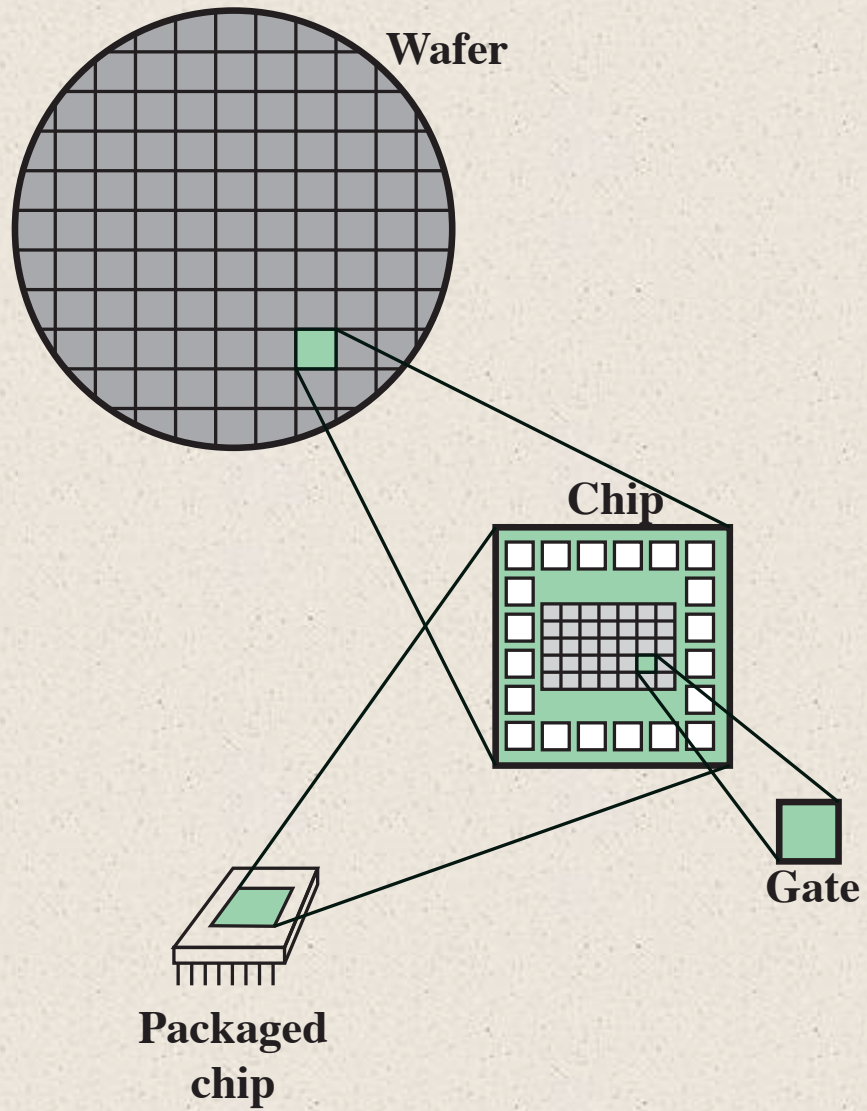

**Figure 1.11 Relationship Among Wafer, Chip, and Gate**

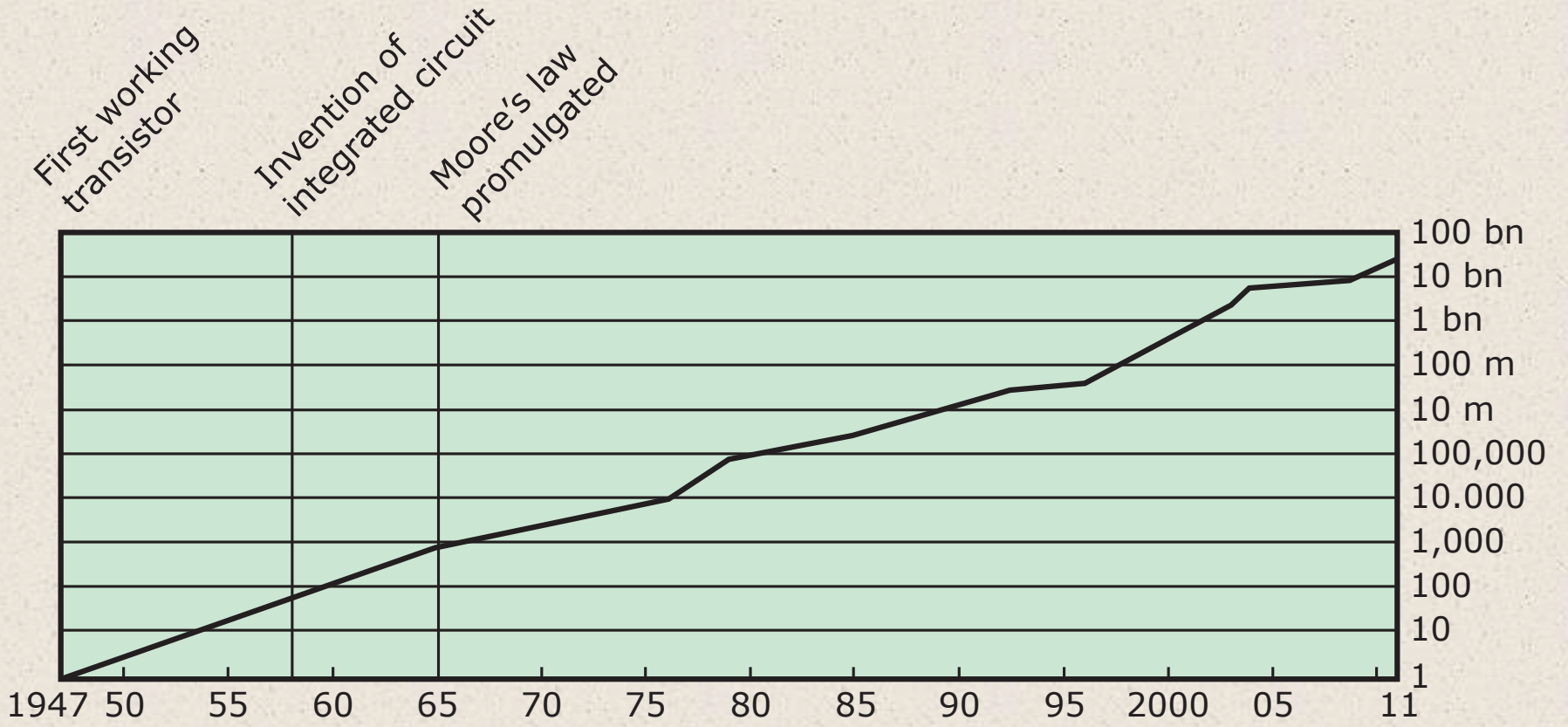

**Figure 1.12 Growth in Transistor Count on Integrated Circuits (DRAM memory)**

# Moore's Law

1965; Gordon Moore – co-founder of Intel

Observed number of transistors that could be put on a single chip was doubling every year

**The pace slowed to a doubling every 18 months in the 1970's but has sustained that rate ever since**

## Consequences of Moore's law:

**The cost of computer logic and memory circuitry has fallen at a dramatic rate**

**The electrical path length is shortened, increasing operating speed**

**Computer becomes smaller and is more convenient to use in a variety of environments**

**Reduction in power and cooling requirements**

**Fewer interchip connections**

# + IBM System/360

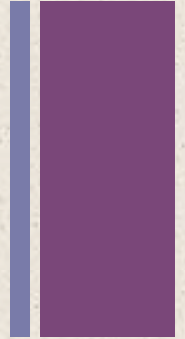

- Announced in 1964
- Product line was incompatible with older IBM machines
- Was the success of the decade and cemented IBM as the overwhelmingly dominant computer vendor
- The architecture remains to this day the architecture of IBM's mainframe computers
- Was the industry's first planned family of computers
  - Models were compatible in the sense that a program written for one model should be capable of being executed by another model in the series



# + Family Characteristics

Similar or identical instruction set

Similar or identical operating system

Increasing speed

Increasing number of I/O ports

Increasing memory size

Increasing cost

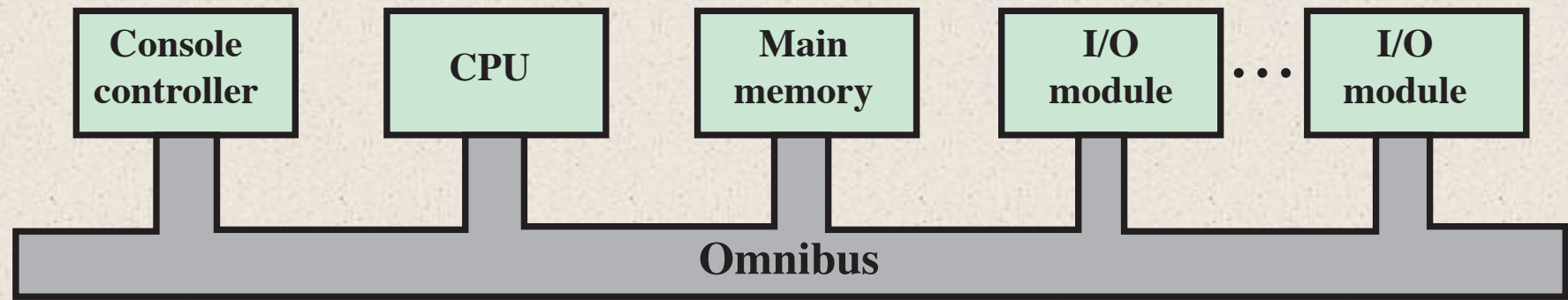

**Figure 1.13 PDP-8 Bus Structure**



# Later Generations

**LSI**  
Large  
Scale  
Integration

**VLSI**  
Very Large  
Scale  
Integration

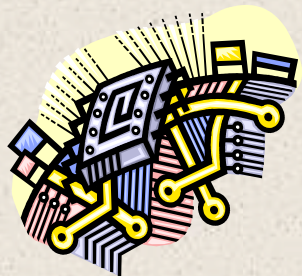

**Semiconductor Memory  
Microprocessors**

**ULSI**  
Ultra Large  
Scale  
Integration



# Semiconductor Memory

In 1970 Fairchild produced the first relatively capacious semiconductor memory

Chip was about the size of a single core

Could hold 256 bits of memory

Non-destructive

Much faster than core

In 1974 the price per bit of semiconductor memory dropped below the price per bit of core memory

There has been a continuing and rapid decline in memory cost accompanied by a corresponding increase in physical memory density

Developments in memory and processor technologies changed the nature of computers in less than a decade

Since 1970 semiconductor memory has been through 13 generations

Each generation has provided four times the storage density of the previous generation, accompanied by declining cost per bit and declining access time



# Microprocessors

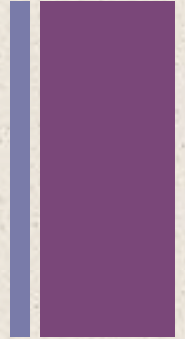

- The density of elements on processor chips continued to rise
  - More and more elements were placed on each chip so that fewer and fewer chips were needed to construct a single computer processor
  
- 1971 Intel developed 4004
  - First chip to contain all of the components of a CPU on a single chip
  - Birth of microprocessor
  
- 1972 Intel developed 8008
  - First 8-bit microprocessor
  
- 1974 Intel developed 8080
  - First general purpose microprocessor
  - Faster, has a richer instruction set, has a large addressing capability



# Evolution of Intel Microprocessors

|                                | <b>4004</b> | <b>8008</b> | <b>8080</b> | <b>8086</b>          | <b>8088</b>  |
|--------------------------------|-------------|-------------|-------------|----------------------|--------------|
| Introduced                     | 1971        | 1972        | 1974        | 1978                 | 1979         |
| Clock speeds                   | 108 kHz     | 108 kHz     | 2 MHz       | 5 MHz, 8 MHz, 10 MHz | 5 MHz, 8 MHz |
| Bus width                      | 4 bits      | 8 bits      | 8 bits      | 16 bits              | 8 bits       |
| Number of transistors          | 2,300       | 3,500       | 6,000       | 29,000               | 29,000       |
| Feature size ( $\mu\text{m}$ ) | 10          | 8           | 6           | 3                    | 6            |
| Addressable memory             | 640 Bytes   | 16 KB       | 64 KB       | 1 MB                 | 1 MB         |

(a) 1970s Processors



# Evolution of Intel Microprocessors

|                                | <b>80286</b>     | <b>386TM DX</b> | <b>386TM SX</b> | <b>486TM DX CPU</b> |
|--------------------------------|------------------|-----------------|-----------------|---------------------|
| Introduced                     | 1982             | 1985            | 1988            | 1989                |
| Clock speeds                   | 6 MHz - 12.5 MHz | 16 MHz - 33 MHz | 16 MHz - 33 MHz | 25 MHz - 50 MHz     |
| Bus width                      | 16 bits          | 32 bits         | 16 bits         | 32 bits             |
| Number of transistors          | 134,000          | 275,000         | 275,000         | 1.2 million         |
| Feature size ( $\mu\text{m}$ ) | 1.5              | 1               | 1               | 0.8 - 1             |
| Addressable memory             | 16 MB            | 4 GB            | 16 MB           | 4 GB                |
| Virtual memory                 | 1 GB             | 64 TB           | 64 TB           | 64 TB               |
| Cache                          | —                | —               | —               | 8 kB                |

## (b) 1980s Processors

# Evolution of Intel Microprocessors

|                                | <b>486TM SX</b> | <b>Pentium</b>    | <b>Pentium Pro</b>    | <b>Pentium II</b> |
|--------------------------------|-----------------|-------------------|-----------------------|-------------------|
| Introduced                     | 1991            | 1993              | 1995                  | 1997              |
| Clock speeds                   | 16 MHz - 33 MHz | 60 MHz - 166 MHz, | 150 MHz - 200 MHz     | 200 MHz - 300 MHz |
| Bus width                      | 32 bits         | 32 bits           | 64 bits               | 64 bits           |
| Number of transistors          | 1.185 million   | 3.1 million       | 5.5 million           | 7.5 million       |
| Feature size ( $\mu\text{m}$ ) | 1               | 0.8               | 0.6                   | 0.35              |
| Addressable memory             | 4 GB            | 4 GB              | 64 GB                 | 64 GB             |
| Virtual memory                 | 64 TB           | 64 TB             | 64 TB                 | 64 TB             |
| Cache                          | 8 kB            | 8 kB              | 512 kB L1 and 1 MB L2 | 512 kB L2         |

## (c) 1990s Processors

# Evolution of Intel Microprocessors

|                       | <b>Pentium III</b> | <b>Pentium 4</b> | <b>Core 2 Duo</b> | <b>Core i7 EE 4960X</b> |
|-----------------------|--------------------|------------------|-------------------|-------------------------|
| Introduced            | 1999               | 2000             | 2006              | 2013                    |
| Clock speeds          | 450 - 660 MHz      | 1.3 - 1.8 GHz    | 1.06 - 1.2 GHz    | 4 GHz                   |
| Bus width             | 64 bits            | 64 bits          | 64 bits           | 64 bits                 |
| Number of transistors | 9.5 million        | 42 million       | 167 million       | 1.86 billion            |
| Feature size (nm)     | 250                | 180              | 65                | 22                      |
| Addressable memory    | 64 GB              | 64 GB            | 64 GB             | 64 GB                   |
| Virtual memory        | 64 TB              | 64 TB            | 64 TB             | 64 TB                   |
| Cache                 | 512 kB L2          | 256 kB L2        | 2 MB L2           | 1.5 MB L2/15 MB L3      |
| Number of cores       | 1                  | 1                | 2                 | 6                       |

## (d) Recent Processors



# + The Evolution of the Intel x86 Architecture

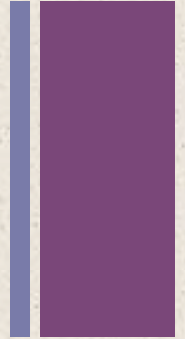

- Two processor families are the Intel x86 and the ARM architectures
- Current x86 offerings represent the results of decades of design effort on complex instruction set computers (CISCs)
- An alternative approach to processor design is the reduced instruction set computer (RISC)
- ARM architecture is used in a wide variety of embedded systems and is one of the most powerful and best-designed RISC-based systems on the market

# Highlights of the Evolution of the Intel Product Line:

## 8080

- World's first general-purpose microprocessor
- 8-bit machine, 8-bit data path to memory
- Was used in the first personal computer (Altair)

## 8086

- A more powerful 16-bit machine
- Has an instruction cache, or queue, that prefetches a few instructions before they are executed
- The first appearance of the x86 architecture
- The 8088 was a variant of this processor and used in IBM's first personal computer (securing the success of Intel)

## 80286

- Extension of the 8086 enabling addressing a 16-MB memory instead of just 1MB

## 80386

- Intel's first 32-bit machine
- First Intel processor to support multitasking

## 80486

- Introduced the use of much more sophisticated and powerful cache technology and sophisticated instruction pipelining
- Also offered a built-in math coprocessor

# Highlights of the Evolution of the Intel Product Line:

## Pentium

- Intel introduced the use of superscalar techniques, which allow multiple instructions to execute in parallel

## Pentium Pro

- Continued the move into superscalar organization with aggressive use of register renaming, branch prediction, data flow analysis, and speculative execution

## Pentium II

- Incorporated Intel MMX technology, which is designed specifically to process video, audio, and graphics data efficiently

## Pentium III

- Incorporated additional floating-point instructions
- Streaming SIMD Extensions (SSE)

## Pentium 4

- Includes additional floating-point and other enhancements for multimedia

## Core

- First Intel x86 micro-core

## Core 2

- Extends the Core architecture to 64 bits
- Core 2 Quad provides four cores on a single chip
- More recent Core offerings have up to 10 cores per chip
- An important addition to the architecture was the Advanced Vector Extensions instruction set



# + Embedded Systems

- The use of electronics and software within a product
- Billions of computer systems are produced each year that are embedded within larger devices
- Today many devices that use electric power have an embedded computing system
- Often embedded systems are tightly coupled to their environment
  - This can give rise to real-time constraints imposed by the need to interact with the environment
    - Constraints such as required speeds of motion, required precision of measurement, and required time durations, dictate the timing of software operations
    - If multiple activities must be managed simultaneously this imposes more complex real-time constraints

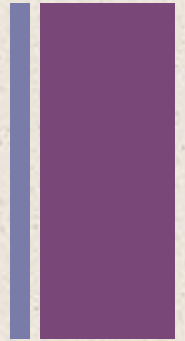

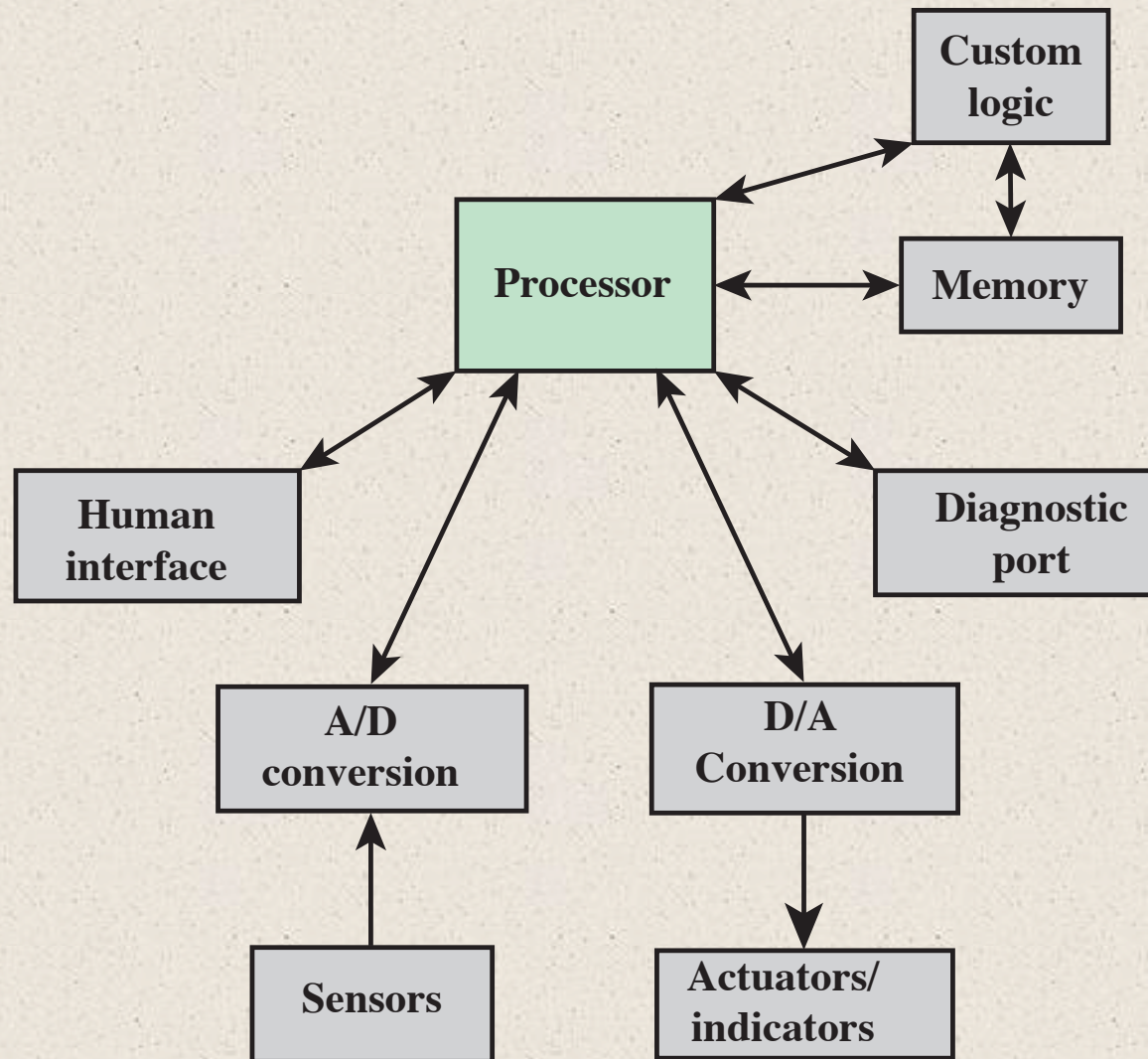

**Figure 1.14 Possible Organization of an Embedded System**

# + The Internet of Things (IoT)

- Term that refers to the expanding interconnection of smart devices, ranging from appliances to tiny sensors
- Is primarily driven by deeply embedded devices
- Generations of deployment culminating in the IoT:
  - Information technology (IT)
    - PCs, servers, routers, firewalls, and so on, bought as IT devices by enterprise IT people and primarily using wired connectivity
  - Operational technology (OT)
    - Machines/appliances with embedded IT built by non-IT companies, such as medical machinery, SCADA, process control, and kiosks, bought as appliances by enterprise OT people and primarily using wired connectivity
  - Personal technology
    - Smartphones, tablets, and eBook readers bought as IT devices by consumers exclusively using wireless connectivity and often multiple forms of wireless connectivity
  - Sensor/actuator technology
    - Single-purpose devices bought by consumers, IT, and OT people exclusively using wireless connectivity, generally of a single form, as part of larger systems
- It is the fourth generation that is usually thought of as the IoT and it is marked by the use of billions of embedded devices





## Embedded Operating Systems

- There are two general approaches to developing an embedded operating system (OS):
  - Take an existing OS and adapt it for the embedded application
  - Design and implement an OS intended solely for embedded use

## Application Processors versus Dedicated Processors

- **Application processors**
  - Defined by the processor's ability to execute complex operating systems
  - General-purpose in nature
  - An example is the smartphone – the embedded system is designed to support numerous apps and perform a wide variety of functions
- **Dedicated processor**
  - Is dedicated to one or a small number of specific tasks required by the host device
  - Because such an embedded system is dedicated to a specific task or tasks, the processor and associated components can be engineered to reduce size and cost



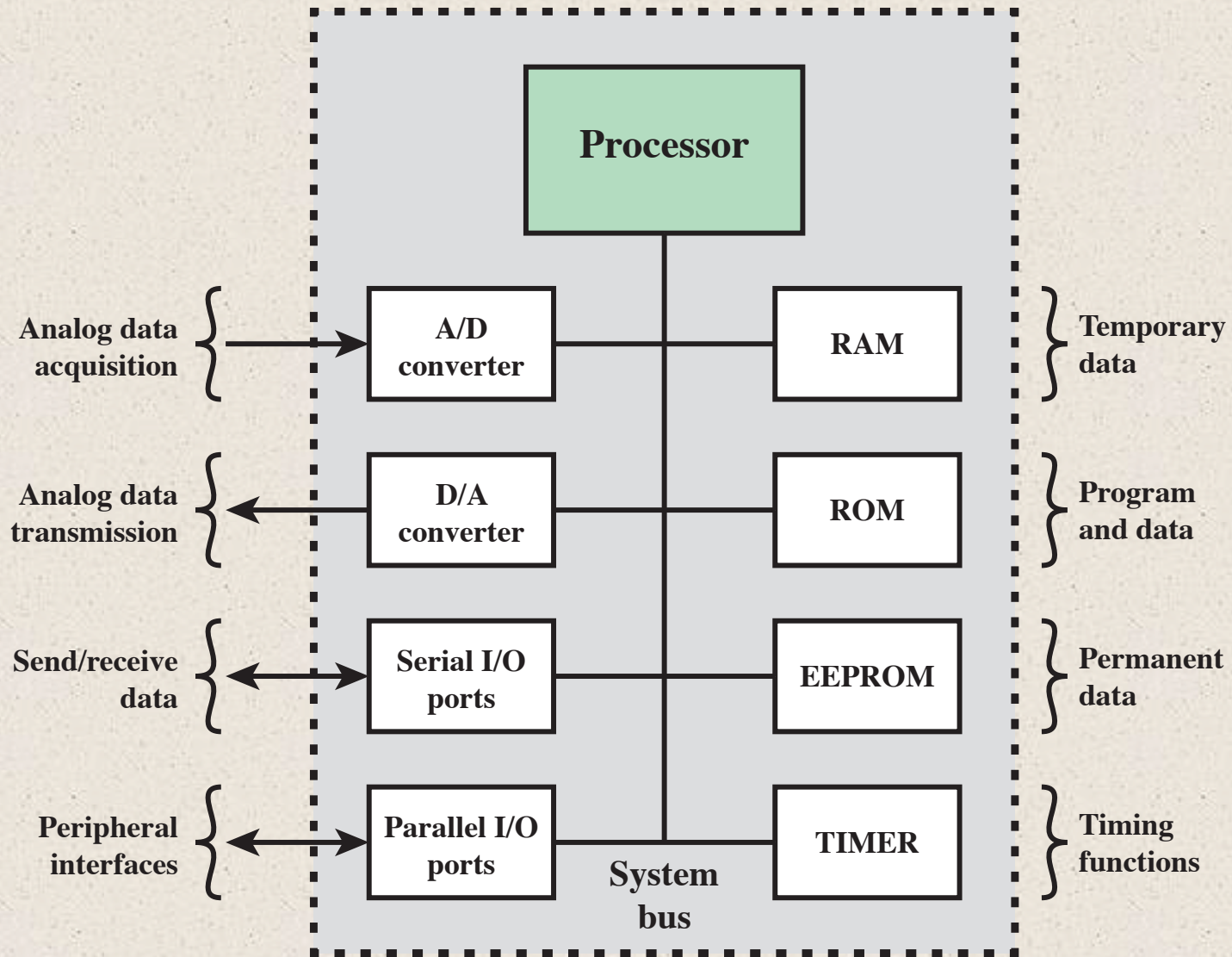

**Figure 1.15 Typical Microcontroller Chip Elements**

# + Deeply Embedded Systems

- Subset of embedded systems
- Has a processor whose behavior is difficult to observe both by the programmer and the user
- Uses a microcontroller rather than a microprocessor
- Is not programmable once the program logic for the device has been burned into ROM
- Has no interaction with a user
- Dedicated, single-purpose devices that detect something in the environment, perform a basic level of processing, and then do something with the results
- Often have wireless capability and appear in networked configurations, such as networks of sensors deployed over a large area
- Typically have extreme resource constraints in terms of memory, processor size, time, and power consumption

# ARM



Refers to a processor architecture that has evolved from RISC design principles and is used in embedded systems

Family of RISC-based microprocessors and microcontrollers designed by ARM Holdings, Cambridge, England

Chips are high-speed processors that are known for their small die size and low power requirements

Probably the most widely used embedded processor architecture and indeed the most widely used processor architecture of any kind in the world

Acorn RISC Machine/Advanced RISC Machine

|  |
|--|
|  |
|  |
|  |
|  |



# ARM Products

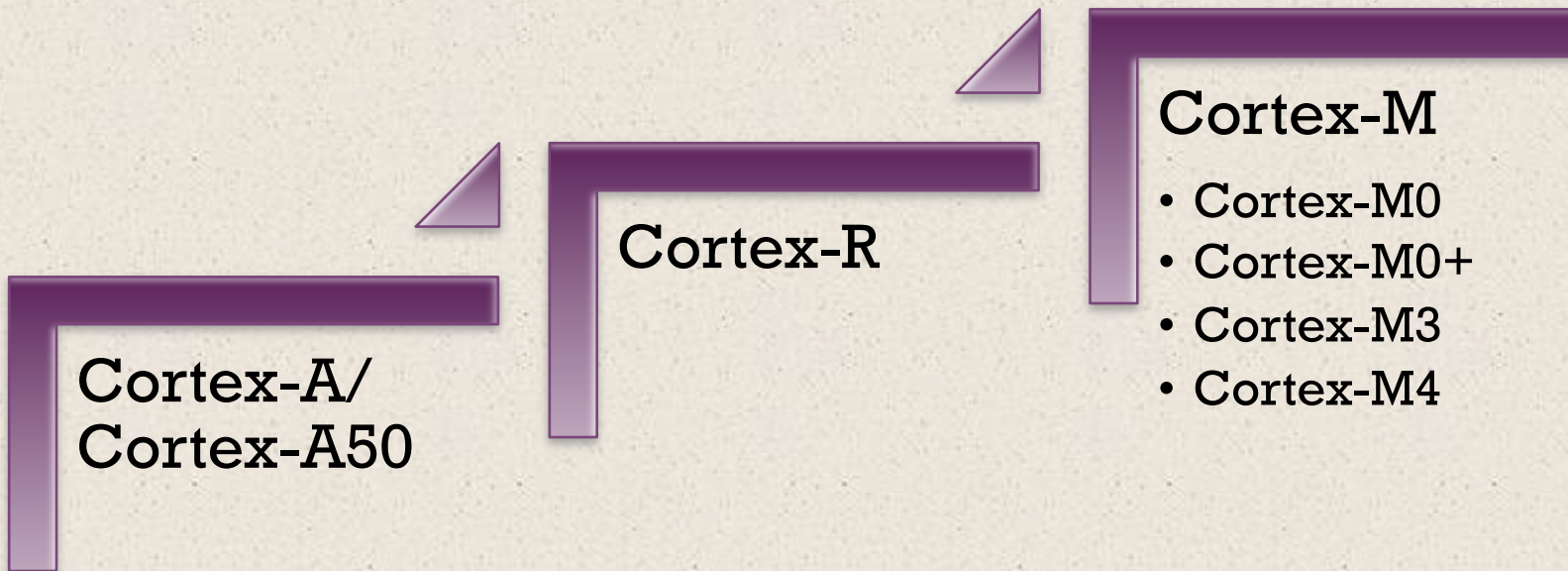
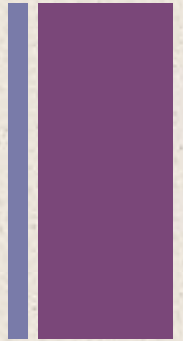



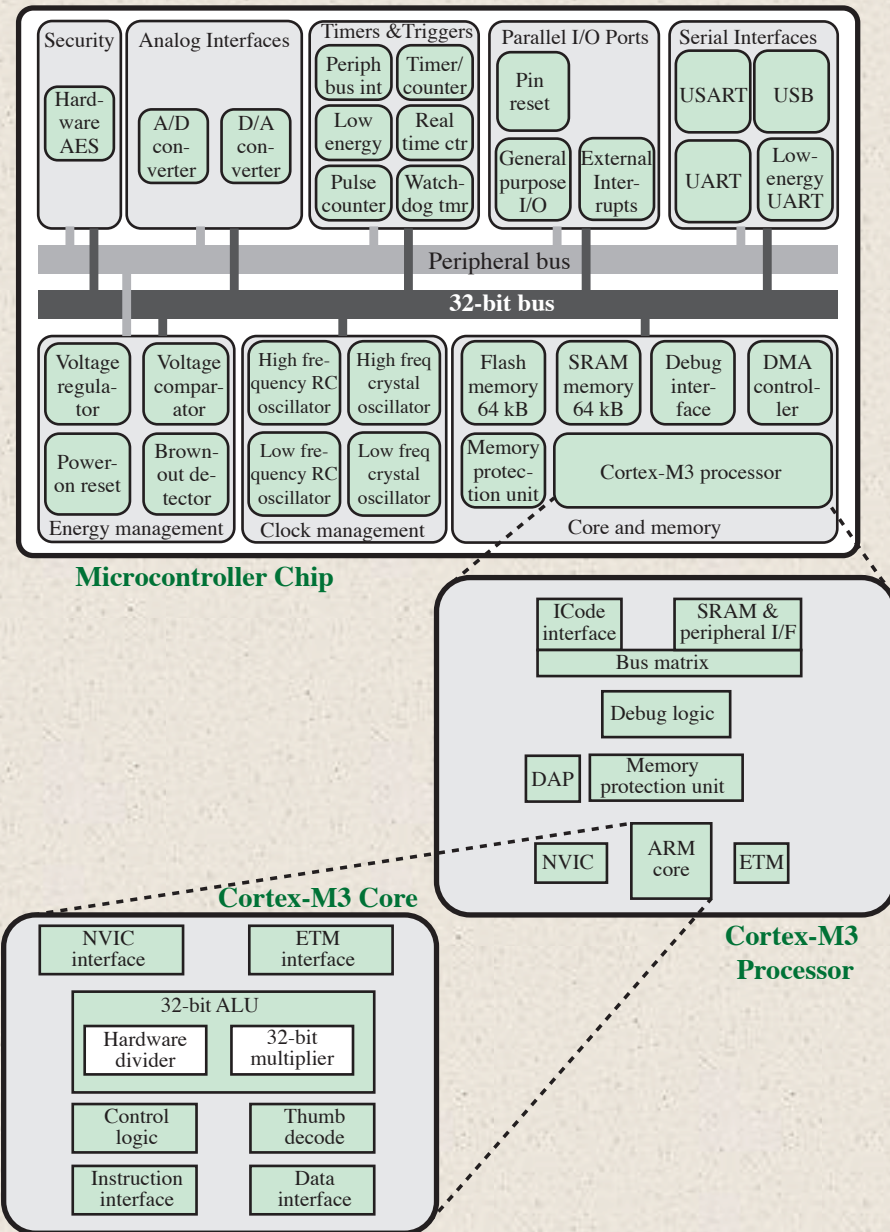

**Figure 1.16 Typical Microcontroller Chip Based on Cortex-M3**

# + Cloud Computing



- NIST defines cloud computing as:

“A model for enabling ubiquitous, convenient, on-demand network access to a shared pool of configurable computing resources that can be rapidly provisioned and released with minimal management effort or service provider interaction.”

- You get economies of scale, professional network management, and professional security management
- The individual or company only needs to pay for the storage capacity and services they need
- Cloud provider takes care of security

# Cloud Networking

- Refers to the networks and network management functionality that must be in place to enable cloud computing
- One example is the provisioning of high-performance and/or high-reliability networking between the provider and subscriber
- The collection of network capabilities required to access a cloud, including making use of specialized services over the Internet, linking enterprise data center to a cloud, and using firewalls and other network security devices at critical points to enforce access security policies

## Cloud Storage

- Subset of cloud computing
- Consists of database storage and database applications hosted remotely on cloud servers
- Enables small businesses and individual users to take advantage of data storage that scales with their needs and to take advantage of a variety of database applications without having to buy, maintain, and manage the storage assets

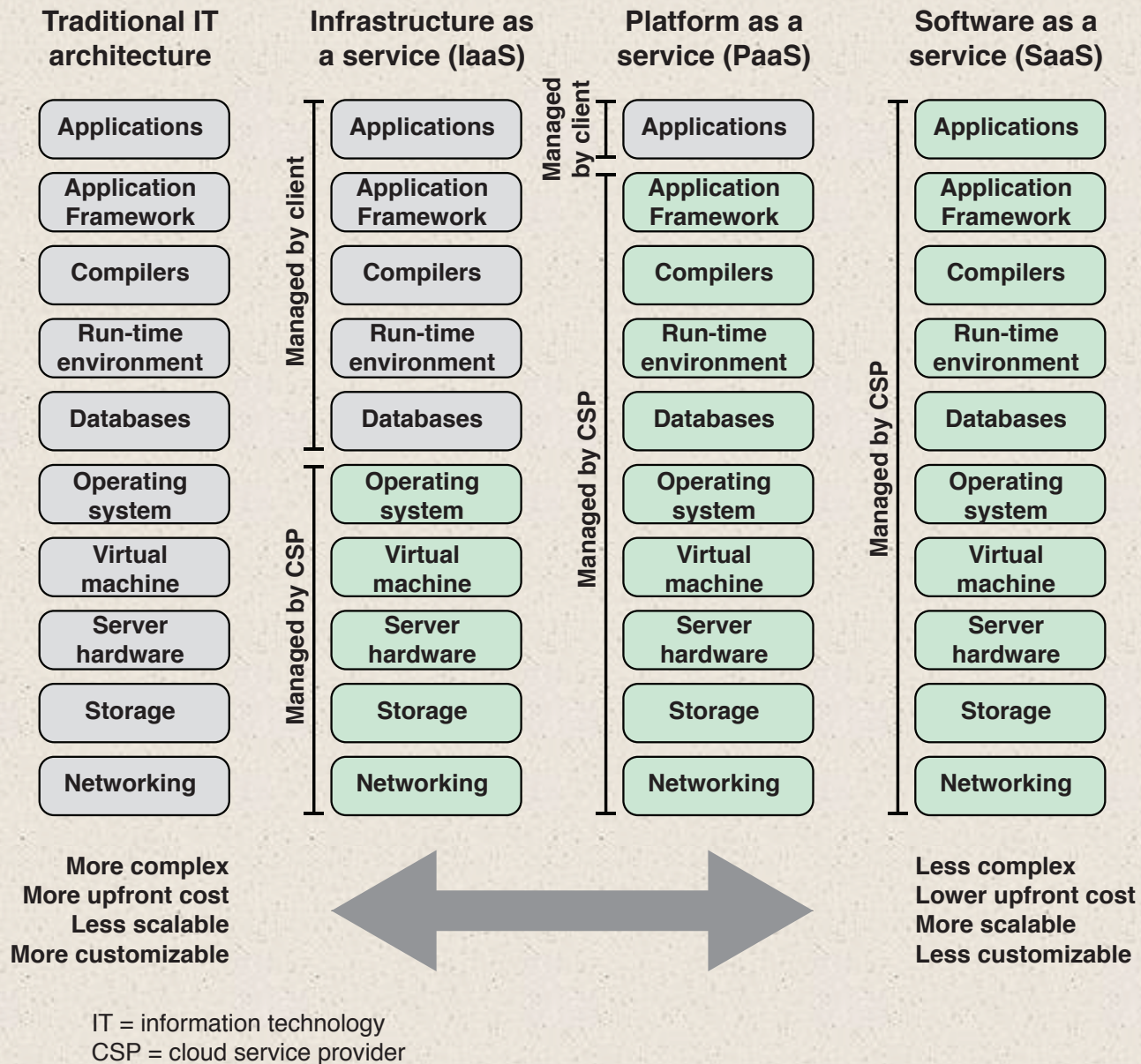

**Figure 1.17 Alternative Information Technology Architectures**



# + Summary

## Chapter 1

- Organization and architecture
- Structure and function
- Brief history of computers
  - The First Generation: Vacuum tubes
  - The Second Generation: Transistors
  - The Third Generation: Integrated Circuits
  - Later generations
- The evolution of the Intel x86 architecture
- Cloud computing
  - Basic concepts
  - Cloud services

## Basic Concepts and Computer Evolution

- Embedded systems
  - The Internet of things
  - Embedded operating systems
  - Application processors versus dedicated processors
  - Microprocessors versus microcontrollers
  - Embedded versus deeply embedded systems
- ARM architecture
  - ARM evolution
  - Instruction set architecture
  - ARM products